

matki

MATKI ONE[®] MOC - CURVED CORNER SLIDER

INSTALLATION

PARTS LIST

PLEASE PASS THE
GUARANTEE CARD ON
TO THE CUSTOMER



MATKI PLC, CHURCHWARD ROAD, YATE, BRISTOL, BS37 5PL
TELEPHONE: 01454 322888 (CUSTOMER SERVICES) EMAIL: techsupport@matki.co.uk

CE

UK
CA

matki

Matki PLC, Churchward Road, Yate,
Bristol BS37 5PL

BS EN 14428:2015+A1:2018

0950 AF 11/21

Matki recommend that this product is fitted by professional installers

IMPORTANT

TOOLS REQUIRED

Masonry Drill bit 6mm, Tape Measure, Screw Drivers, Safety Glasses, Electric Drill, Level, Pencil, Adjustable Spanners, Non Slip Gloves, 2mm & 4mm Allen Key

Before disposing of carton and/or commencing assembly, please check all the parts to ascertain that none are missing and they are all undamaged. No claim for missing/damaged parts will be accepted once the packing carton has been disposed of and/or assembly has commenced.

In case of query contact your Stockist with details of model number and details of serial number.

PREPARATION IMPORTANT

1. Please read complete installation instructions before fitting for Enclosure and Tray (if fitting).
2. We recommend the use of Safety glasses and Non slip gloves when handling the glass panels.
3. Ensure that the product can be **fixed** to a **solid masonry wall** or suitable **timber stud work grade C16/C24** in the area behind the Wall frames.
4. Shower trays or tiled floors **must be absolutely level** where enclosures are fitted
5. If fitting a tray we recommend a **drainage test** is carried out before the tray is tiled in position.
6. The assembly should be installed onto a waterproof wall covering and installed after the Tray and wall coverings are in place. Where Tiling lips are provided Trays should be let into the Wall with the Tiling lip flush with the wall to allow the Tiling to overlap the Tiling lip.
7. Seal between tray and tiles. Remove any excess sealant from the area/joint between the tray and the tiles where the Wall Mount is to be fitted. This will ensure the Wall mount fits correctly to the wall and tray/or tiled floor.

CAUTION: TEMPERED GLASS CANNOT BE CUT, POLISHED METAL AND CHROME CAN BE SCRATCHED. CAREFULLY REMOVE ASSEMBLY FROM CARTON, DO NOT PLACE GLASS ON HARD FLOOR OR EXPOSE EDGES TO IMPACT.

DIMENSIONS

CURVED CORNER SLIDER

900 X 900 / 900 X 1000
900 X 1200 / 900 X 1500

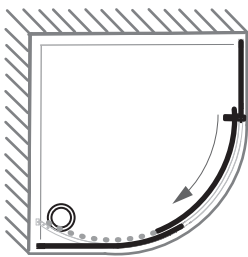

LH CORNER

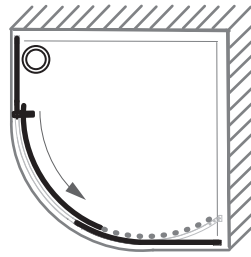

RH CORNER

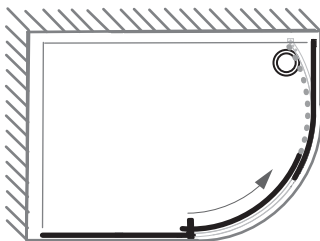

LH CORNER

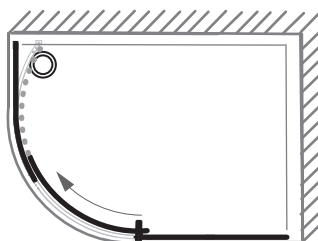

RH CORNER

Model	A	B
MOC900	870-890	310-330
MOC1090	970-990	410-430
MOC1290	1170-1190	610-630
MOC1590	1470-1490	910-930

Dimensions are approximate

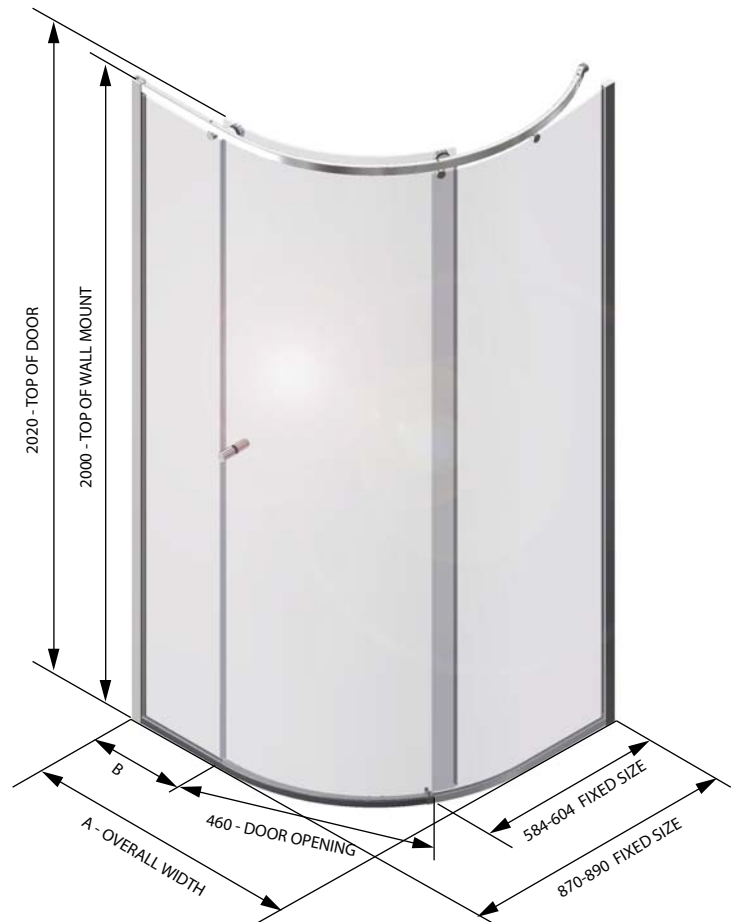

CONFIGURATIONS



MOC LH OPENING



MOC RH OPENING

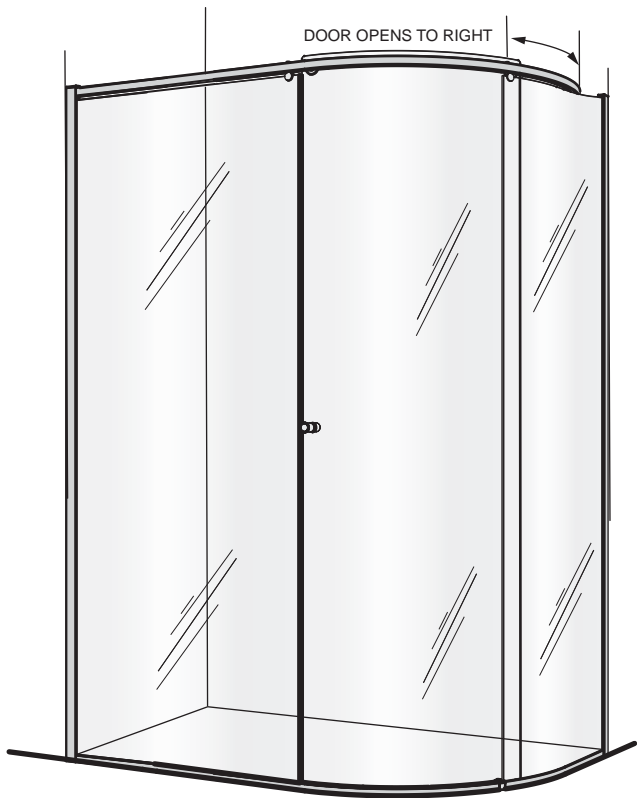

1000/1200/1500 MOC LH CORNER (OFFSET)



1000/1200/1500 MOC RH CORNER (OFFSET)

STAGE 1

INSTALLATION FOR A RH OPENING UNIT

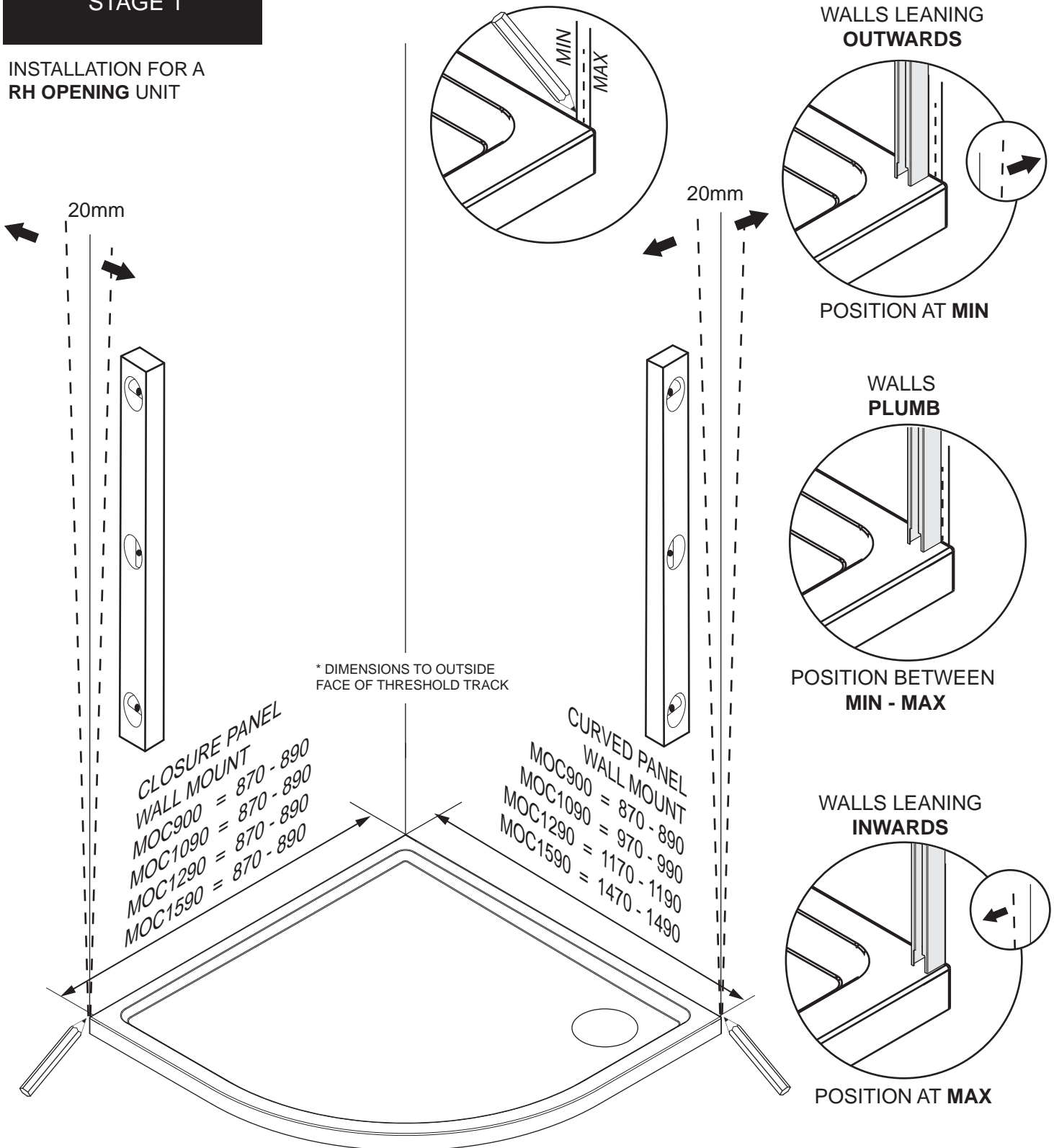

This stage is describing the placement of the Curved fixed panel wall mount and straight fixed panel wall mount.

The fixed panels have adjustable wall mounts to compensate for size adjustment or out of plumb walls or a combination of adjustment and out of plumb. There is 20mm of adjustment in each wall mount.

Check the walls for upright and that the product dimensions will fit the situation before installation.

Mark out the MIN and MAX adjustment ranges on the wall.

If the walls are PLUMB, position the wall mounts between the MIN and MAX marks.

If the walls are leaning OUTWARDS, position the wall mounts at the MIN marks.

If the walls are leaning INWARDS, position the wall mounts at the MAX marks.

STAGE 2

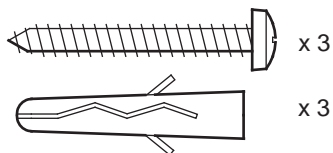

THIS PAGE SHOWS THE PANEL INSTALLATION FOR A RH DOOR OPENING.

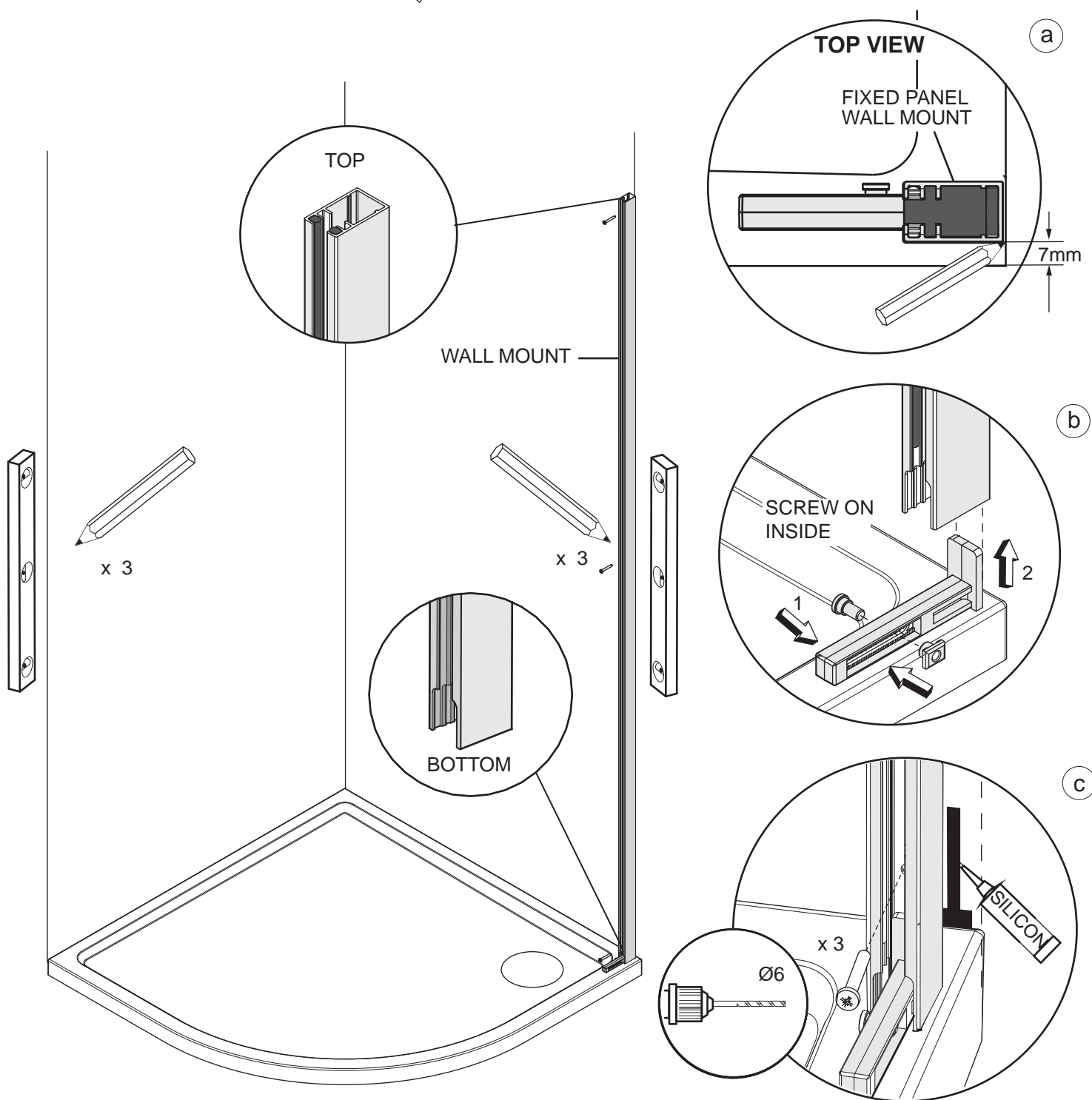

This stage is describing the fitting of the Fixed Curved panel wall mount.

a. The Curved fixed panel wall mount has a top and bottom (Cut out at the bottom of wall mount). Position the wall mount as required plumb the wall mount for upright mark the fixing holes in the centre of the slots. Drill 3 x fixing holes in the wall and insert the wall plugs. Clean the area.

b. Before fitting the wall mount fit the curved panel floor rail adjuster (supplied in the kit of parts) into the bottom of the wall mount. The adjuster clamping screw must face inwards, remove and refit the screw and nut assembly with the screw on the inside if required. Fit the adjuster up the back of the wall mount in the recess shown.

c. Apply silicon sealant to the area behind the wall mount between the tray and tiles and 100mm up the wall, central to the width of the wall mount. Fit the wall mount using the No.8 x 38mm pan head screws.

STAGE 3

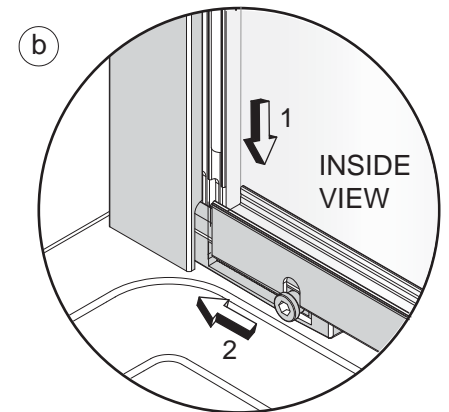
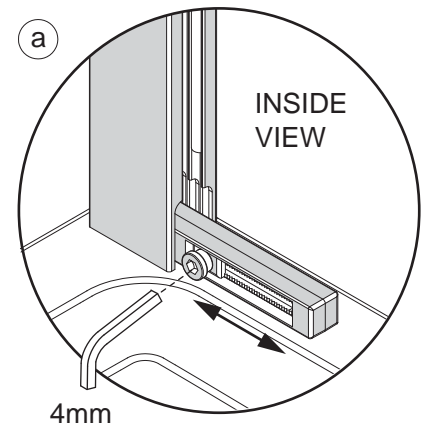
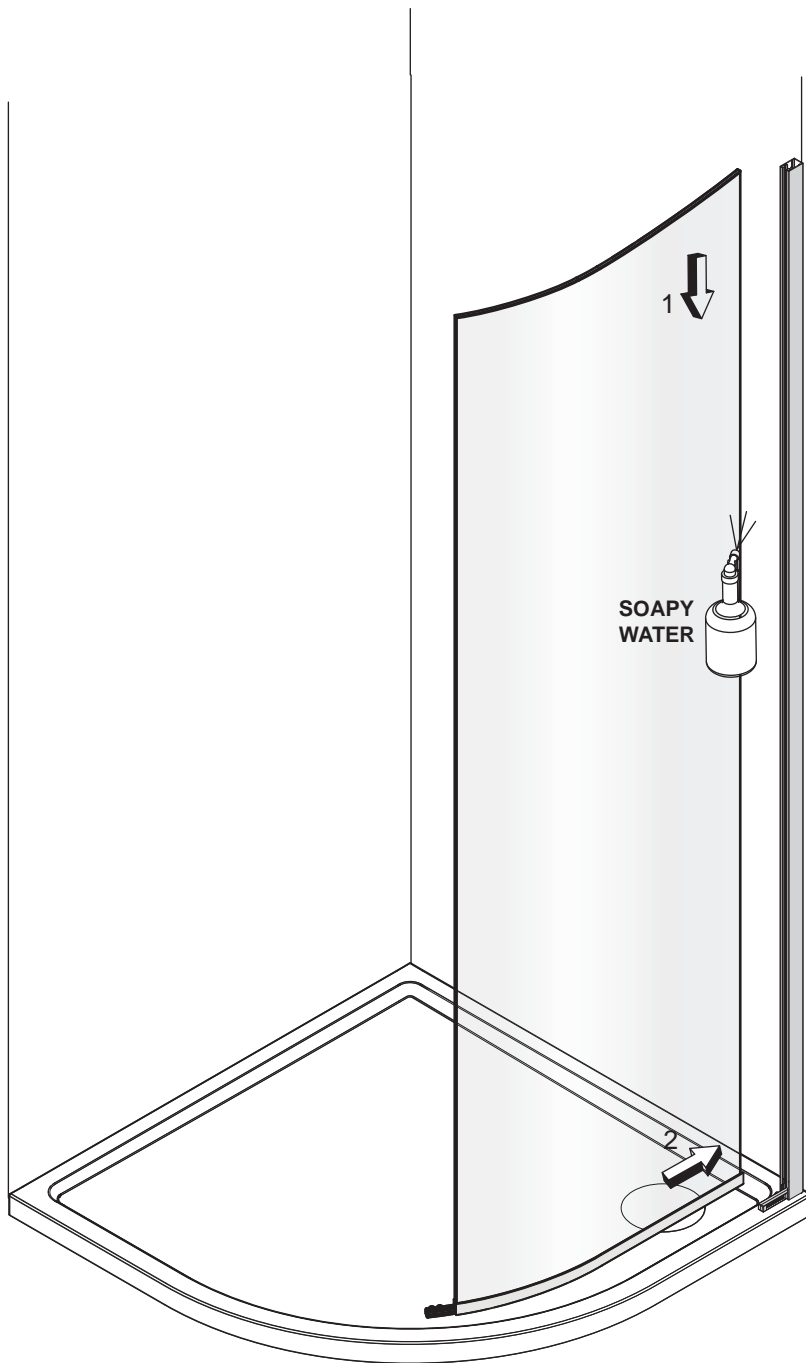

This stage is describing the fitting of the Fixed Curved panel.

- a.** Loosen the screw on the floor rail adjuster bracket so that it is at the maximum adjustment and can move freely.
- b.** Lightly wet the edge of the fixed panel with soapy water gently lower the fixed curved panel onto the adjuster ensuring the adjuster screw locates into the notch on the inside of the curved panel floor rail. Then gently push the fixed glass panel into the wall mount.

STAGE 4

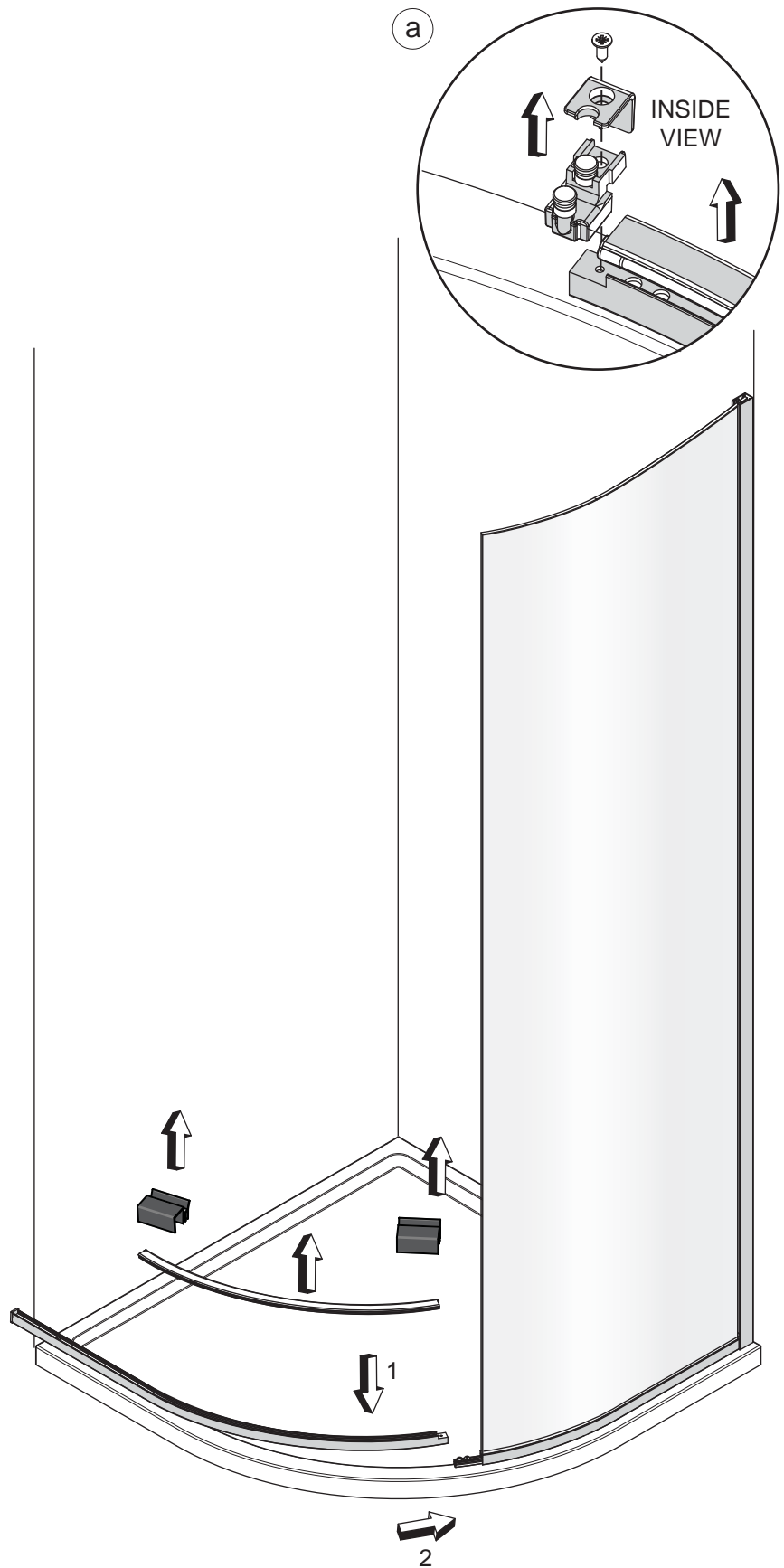
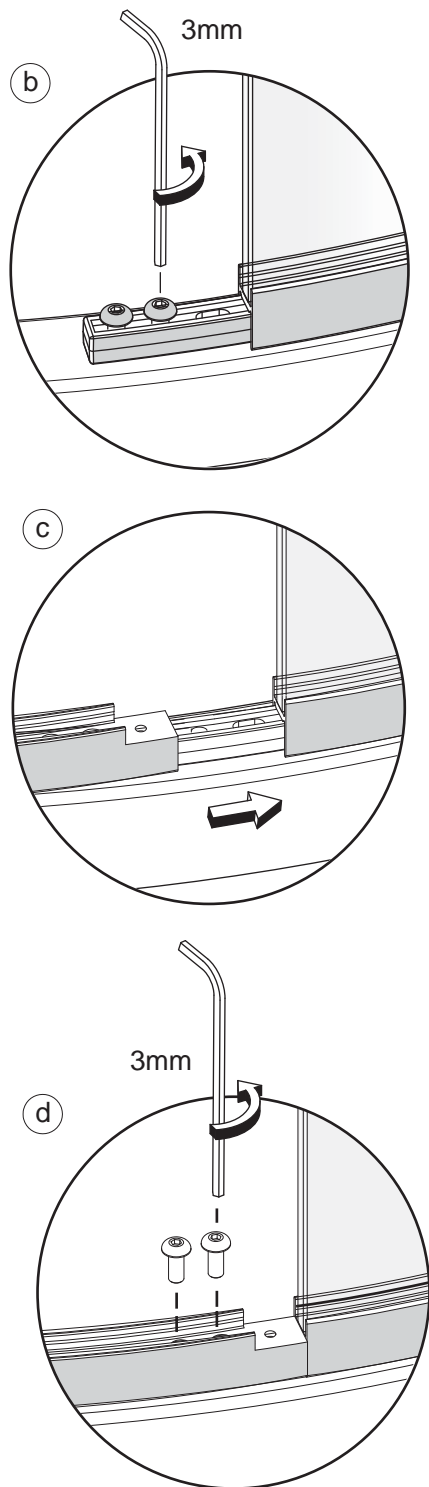

This stage is describing the fitting of the floor rail.

- a.** Remove the factory assembled guide block from the floor rail and threshold cover. Carefully set aside for re-fitting.
- b.** Before fitting the floor rail remove and set aside the 2 x M5 x 12 socket screws from the floor rail bracket in the end of the curved fixed panel.
- c.** Fit the floor rail over the floor rail bracket until it meets the curved fixed panel. Ensure the joint is tight between the floor rail and fixed panel and secure with 2 x M5 x 12 socket screws using the 3mm allen key.

STAGE 5

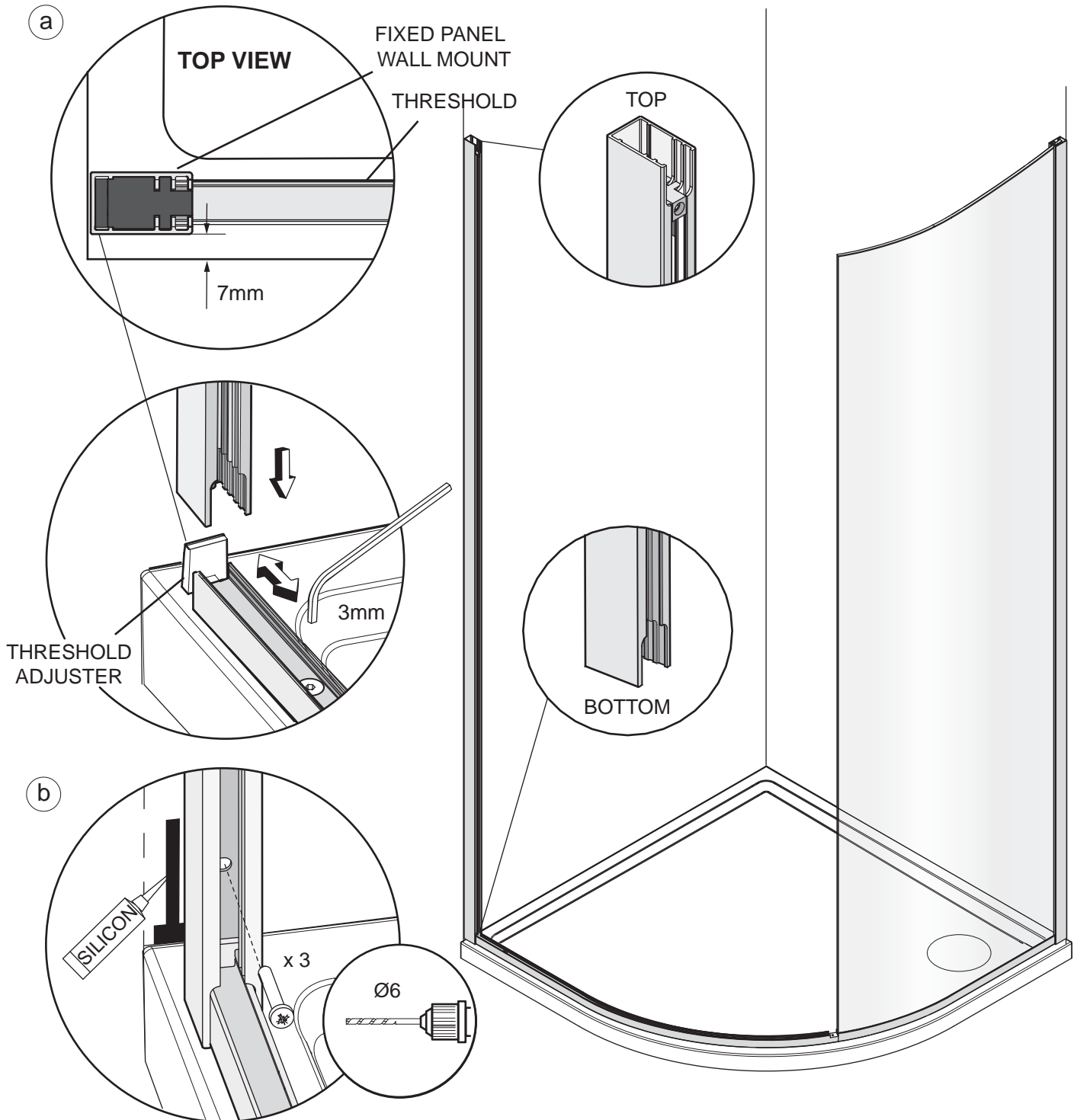

This stage is describing the fitting of the Straight fixed panel wall mount.

a. Position the wall mount on to the wall over the floor rail (Wall mount has a top and bottom, wall mount cut-out with socket set screw is the top of the wall mount). Ensure the threshold adjuster fits up into the back of the wall mount extrusion in the recess shown. Adjust the position of the threshold adjuster as required to align the curved floor rail evenly from the front edge of the tray.

To adjust loosen the screw 1 full turn, re-tighten after adjustment, do not over tighten. Plumb the wall mount for upright and mark the fixing holes in the centre of the slots.

b. Drill 3 x fixing holes in the wall and insert the wall plugs. Clean area and apply silicon sealant to the area behind the wall mount between the tray and tiles and 100mm up the wall, central to the width of the wall mount. Fit the wall mount using the No.8 x 38mm pan head screws.

STAGE 6

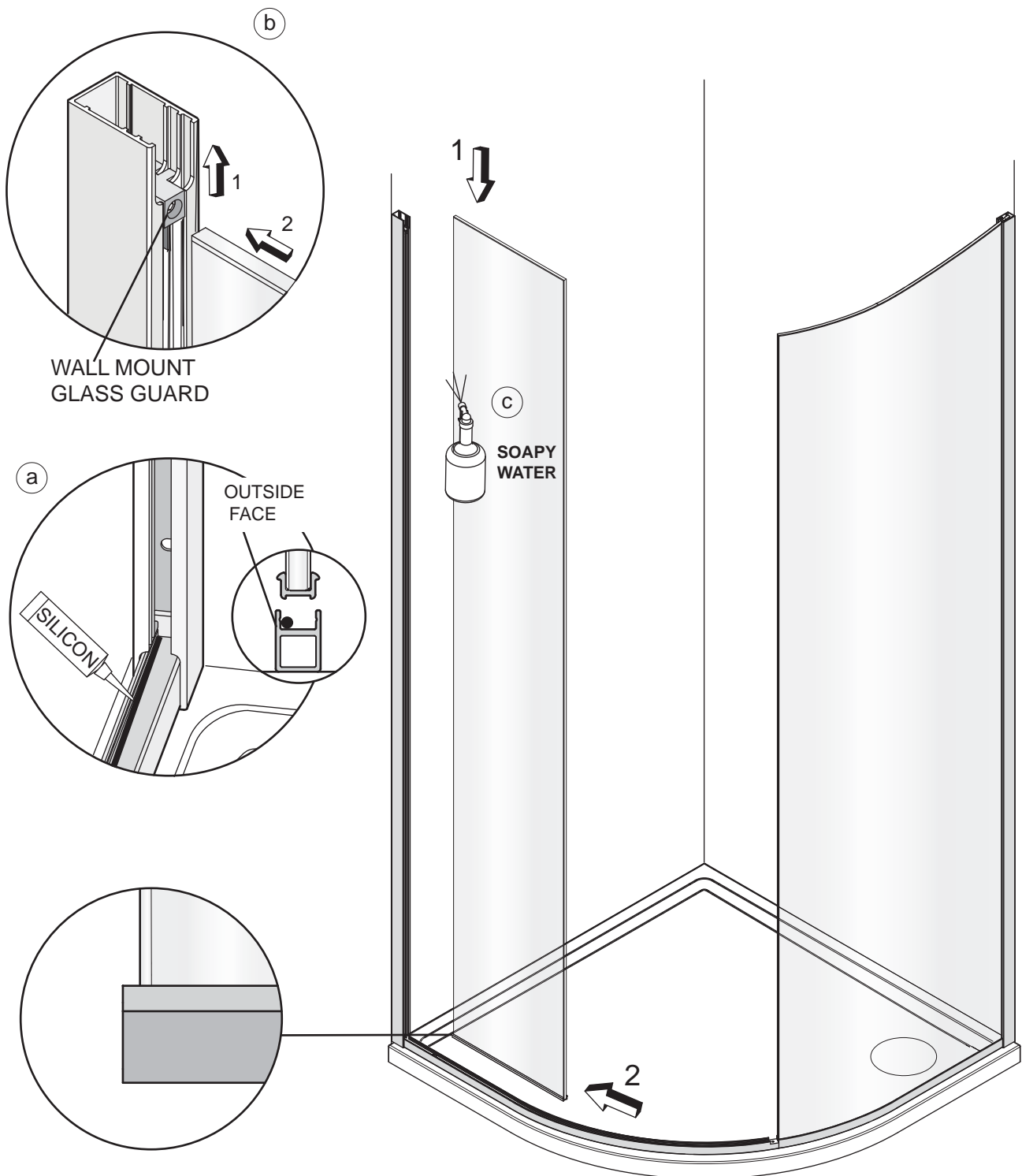

This stage is describing the fitting of the straight fixed panels.

- Apply a bead of silicon along the full length of the outer inside edge recess of the straight fixed panel floor rails where the fixed panel is to be fitted.
 - Before fitting the fixed panels ensure that the wall mount glass guard is pushed up fully to allow the glass to easily slot into the wall mount.
- Important** -The frame on the bottom of the fixed glass panel is slightly longer than the glass on one side. The opposite side is factory assembled to be flush. Fit the fixed glass panel with the longer end bottom frame into the wall mount.
- Lightly wet the edge of the fixed panel with soapy water and gently lower the panel into the floor rail then into the wall mount.

STAGE 7

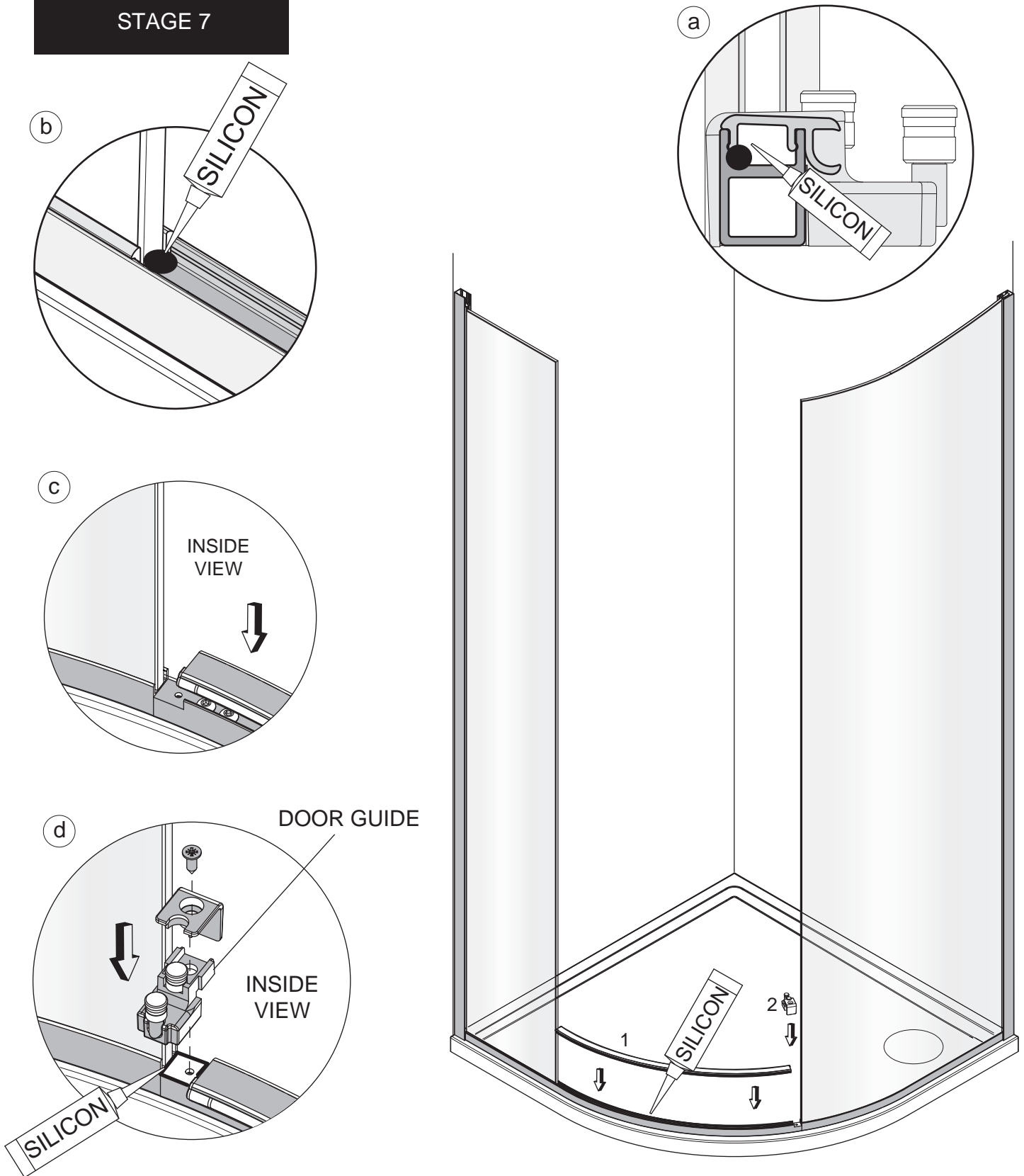

This stage is describing the fitting of the threshold and guide block.

- a.** Apply a bead of silicon sealant along the outer inside edge of the floor rail in the door entrance where the threshold cover is to be fitted.
- b.** Apply a bead of silicon in the floor rail at the end face of the straight fixed panel where the threshold cover is to be fitted.
- c.** Fit the curved threshold cover onto the floor rail.
- d.** Apply a small bead of silicon to the joints between the guide and floor rail, glass and guide, guide and threshold cover. Refit the guide. Adjust the straight fixed panel if required to close any gap between the glass and threshold cover.

STAGE 8

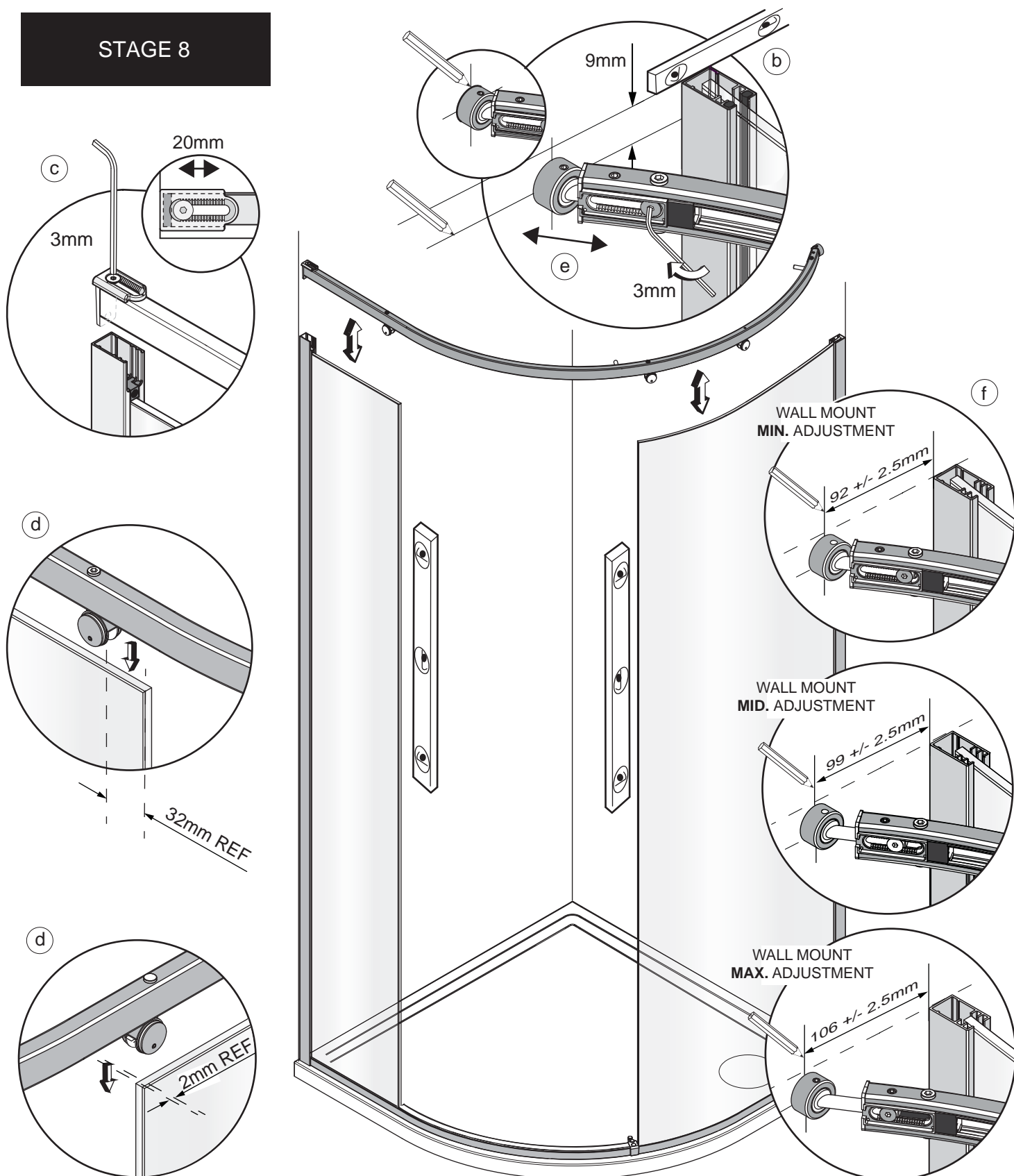

This stage is describing the temporary fitting of the top track to position the top track wall fixing.

- Before fitting the top track plumb the glass panels to check for vertical.
- Level a horizontal pencil line from the top of the Curved fixed panel wall mount. Mark a parallel line 9mm below the level line for the centre reference of the top track wall fixing.
- Loosen the top track wall mount cap and top track wall fixing adjuster to allow for fitting the top track.
- Lower the top track into position, ensuring the top track glass clamps fit over the top edge of glass panels and the wall mount top cap fits down the back of the wall mount at the top. Check the reference dimensions for the clamps to the edge of the glass panels.
- Adjust the top track wall fixing adjuster to the wall. Centre the cylindrical fixing plate on the 9mm reference line and mark around to determine the fixing centre. Remove the top track and carefully set aside.
- The position of the wall fixing adjuster from the inside of the wall mount will vary depending on the adjustment/position of the glass within the wall mount.

STAGE 9

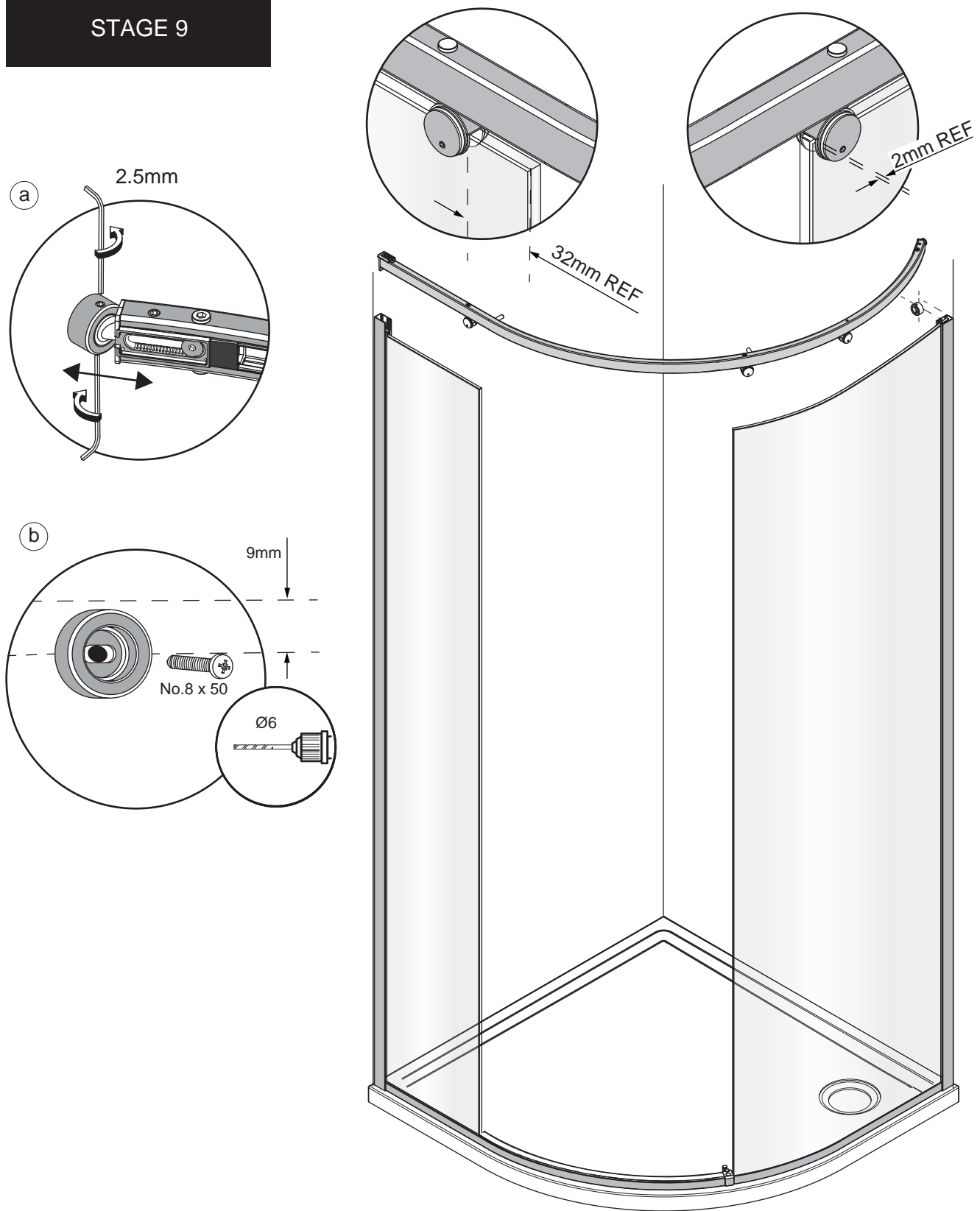

This stage is describing the fitting of the top track.

- Remove the top track wall plate from the adjuster by loosening the set screws in the top and bottom using the 2.5mm allen key. Place the wall plate on the wall (slot horizontal) on the previously marked position and mark the slot position.
- Drill the fixing hole in the centre of the slot and insert the wall plug. Secure the wall plate using the No.8 x 50mm pan head screw aligning the slot in the horizontal position.
- Lower the top track into position, ensuring the top track glass clamps fit over the top edge of glass panels and the wall mount top cap fits down the back of the wall mount at the top and the wall adjuster is fitted into the wall plate. Adjust as required checking the reference dimensions for the clamps to the edge of the glass panels. a. Tighten the wall adjuster to the wall plate with the set screws in the top and bottom of the wall plate using the 2.5mm allen key.

STAGE 10

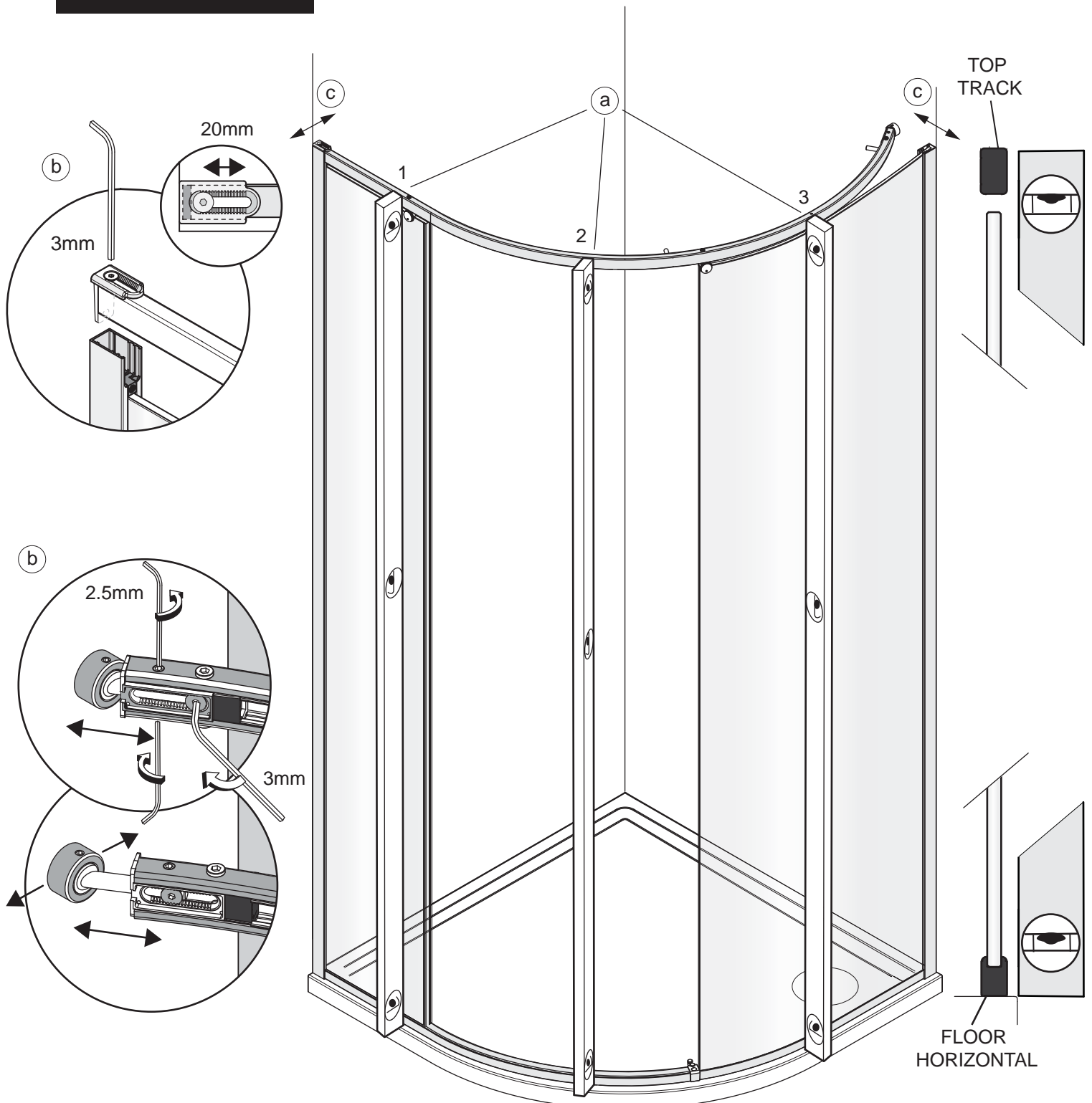

This stage is describing checking that the Top track and Bottom track are concentric.

a. It is important for the smooth operation of a curved enclosure that the top track and bottom track curvatures are concentric. Check the concentricity by carefully placing a long 2m level between the outside face of the top and bottom track in the 3 positions shown and check for vertical. Vertical will indicate that the curvatures are matching. Protect the top and bottom tracks from scratches with masking tape on the face of the level to prevent metal to metal contact.

b. If not vertical then adjustment may be required to the top track position via the adjustment in the top of the wall mount and wall adjuster in the top track. Adjusting these will move the top of the fixed glass panels and clamping positions outwards or inwards as required. It may be necessary to move the wall adjuster plate horizontal position using the slot in the base of the part. Stage 9b.

c. The track position can also be moved outwards or inwards by carefully tapping the wall mounts out of vertical via the slotted holes in the wall mounts. This will effectively move the fixed glass panels inwards or outwards at the top by the wall. Protect the wall mount metal surfaces from damage if adjusting by tapping out of vertical.

STAGE 11

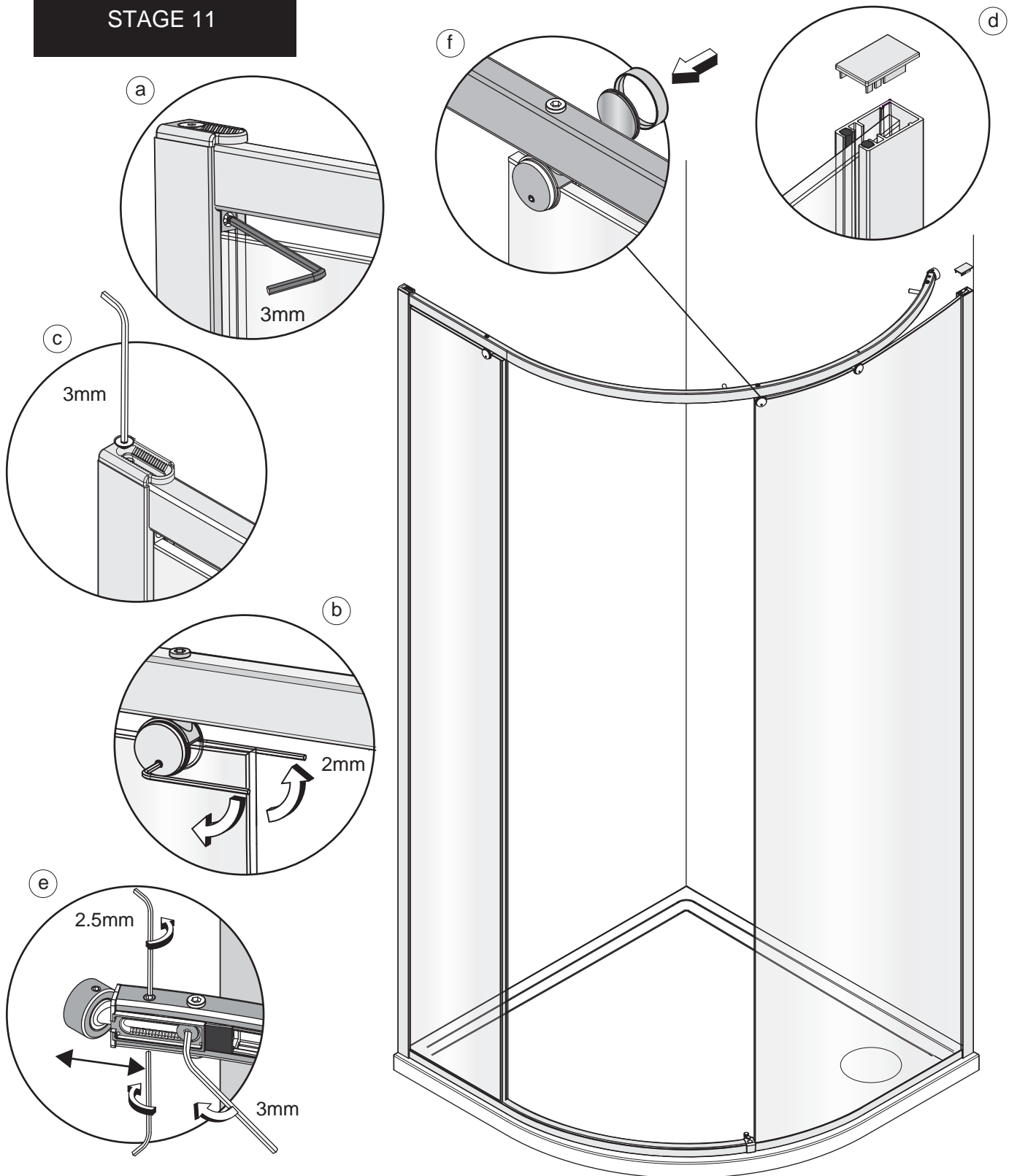

This stage is describing the final fitting of the top track.

- a. Important** – Tighten the top track locking screw underneath the top track on the fixed straight panel wall mount with the 3mm allen key.
- b.** Tighten the top track glass clamps by tightening the socket set screws on both sides with the 2mm allen key. Important – Please ensure the grey coloured glass clamp guards are fitted between the clamps and glass panels before tightening the set screws. Do not over tighten.
- c.** Tighten the wall mount cap adjuster screw with the 3mm allen key.
- d.** Fit the Curved fixed panel wall mount top cap.
- e.** Fully tighten the top track wall adjuster screw using the 3mm allen key. Tighten the wall adjuster locking screws through the small holes on the top and underside of the top track with the 2.5mm allen key.
- f. Important** – Before fitting the door. Fit one of the block covers (supplied in the kit of parts) onto the disc, on the curved panel, on the inside of the unit.

STAGE 12

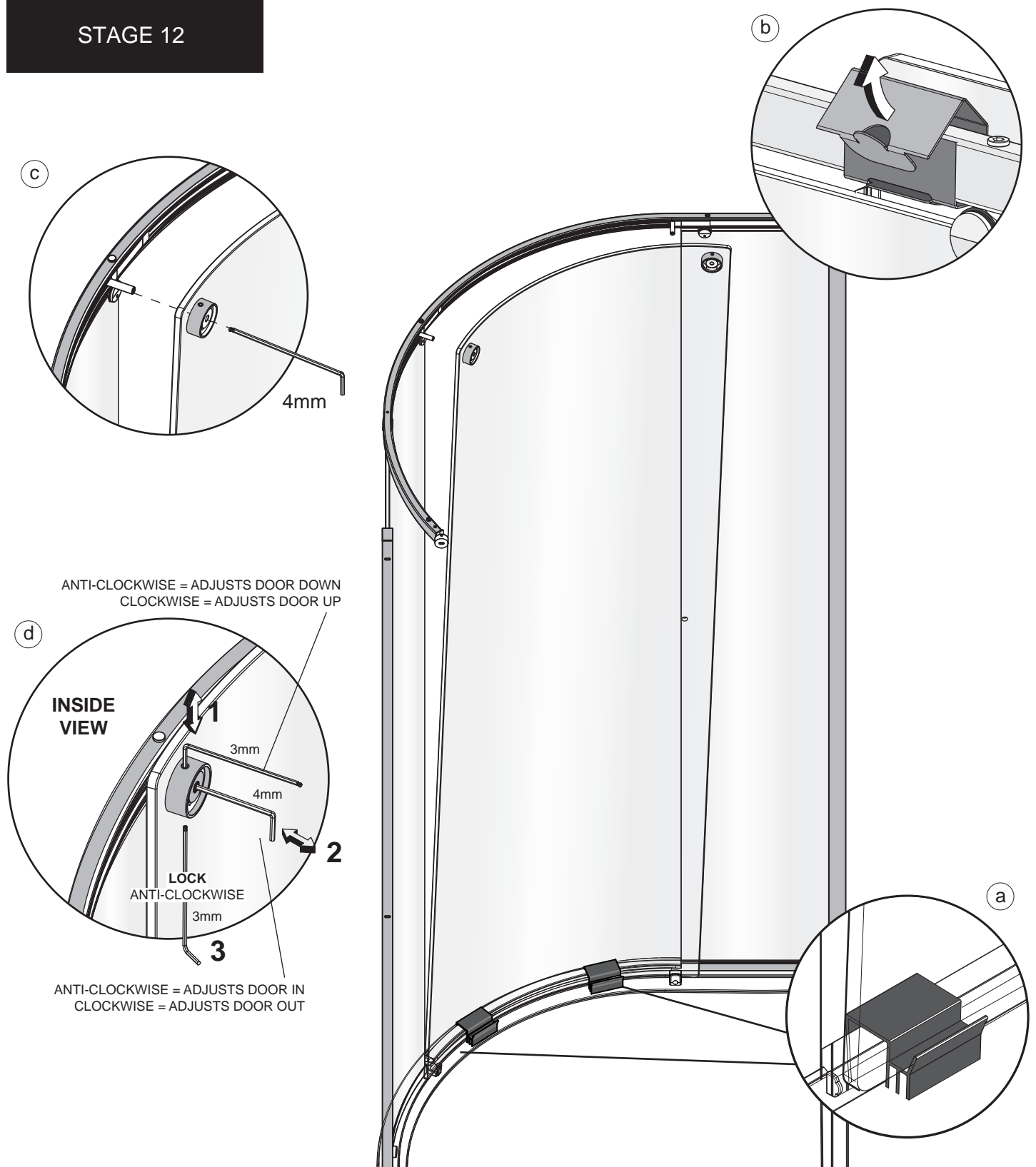

This stage is describing attaching the door.

a. Important - Fit the plastic door supports to the Threshold track at either side of the Door opening.

b. Load the door glass firstly onto the door supports and guide block and then carefully guide the door up to the door roller threads and wind them through the door roller blocks fixed to the glass. .

c. Remove both the cardboard top track door roller guides by pulling the tabs and unfolding them away from the top track.

d. Adjust the door panel if required so that it runs parallel to the door opening by adjusting the Roller blocks on the inside of the door. To adjust the door away from the top track rotate the central set screw clockwise using the 4mm allen Key. To adjust the door to the top track, rotate the central set screw anti-clockwise.

d. The door glass can also be raised or lowered by the adjustment screw in the top of the roller block using the 3mm allen key supplied. Rotate clockwise to raise the door, rotate anti-clockwise to lower the door.

d. **Lock** the adjustment by rotating the set screw anti-clockwise in the bottom of the roller block using the 3mm allen key supplied.

STAGE 13

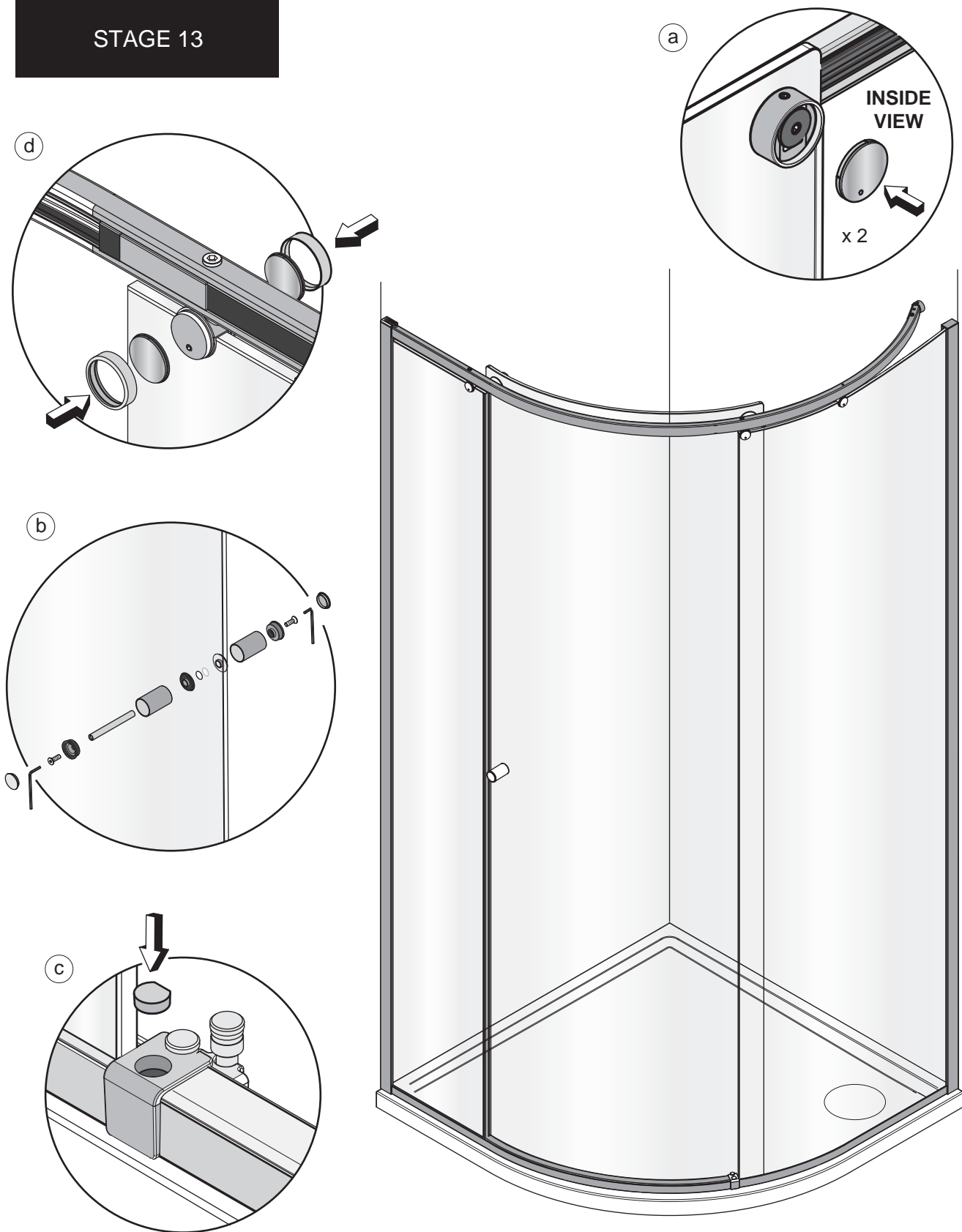

This stage is describing the fitting of the handle and colour details.

- a.** Fit the 2 x door roller block covers (supplied in the kit of parts) to the back of the door roller blocks.
- b.** Disassemble the handle by unscrewing the 2 x M5 x 16 Csk socket screws. Place the glass washers either side of the 2 holes in the door glass. Re-assemble the handle to the glass and tighten into position. Fit the Cover caps (supplied in the kit of parts) to either side of the handle.
- c.** Fit the door guide screw cover (supplied in the kit of parts) to the door guide.
- d.** Fit the 6 x panel block covers (supplied in the kit of parts).

STAGE 14

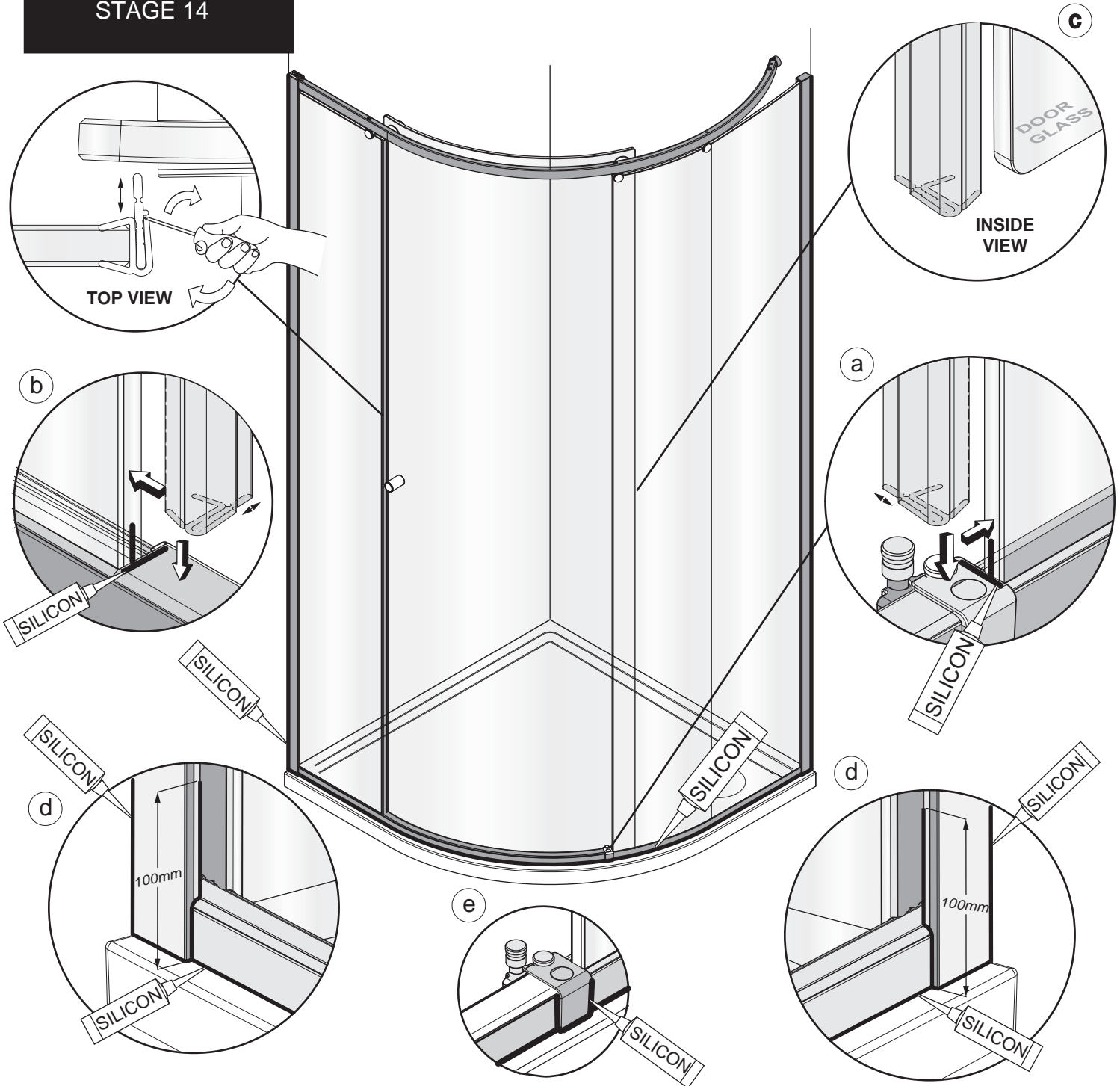

This stage is describing fitting of the Seals and Silicon

- Apply a bead of silicon along the top of the door guide. Fit the fixed panel vertical seal (shorter of the 3 seals) to the edge of the fixed panel, ensuring it is pressed firmly against the face of the door guide.
- Apply a bead of silicon along the top of the threshold cover where it meets the closure panel. Fit the closure panel vertical seal to the edge of the closure panel, ensuring the seal sits firmly down onto the face of the threshold cover.
- Fit the door vertical seal to the back edge of the door glass, the bottom of the seal should be lined up with the top of the floor horizontal.
- Apply a thin bead of silicon along the bottom edge of both the wall mounts and all the way up the outside of both the wall mount extrusions between the wall mounts and the tiles. Apply a thin bead all the way along the threshold between the extrusion and the finished floor surface/tray around the corner extrusion and along the bottom of the side panel where it meets the floor/tray. Continue around the joint where the threshold joins the wall mounts and also 100mm up on the outside where the wall mounts and glass meet and where the corner extrusion and glass meet. Apply a bead of silicon on the outside around the joints between the door guide and threshold extrusion (e).

Masking tape can be used to achieve a tidy edge to the sealant. Remove the masking tape immediately and allow the silicon to cure for 24 hours before using the shower.

PARTS LIST

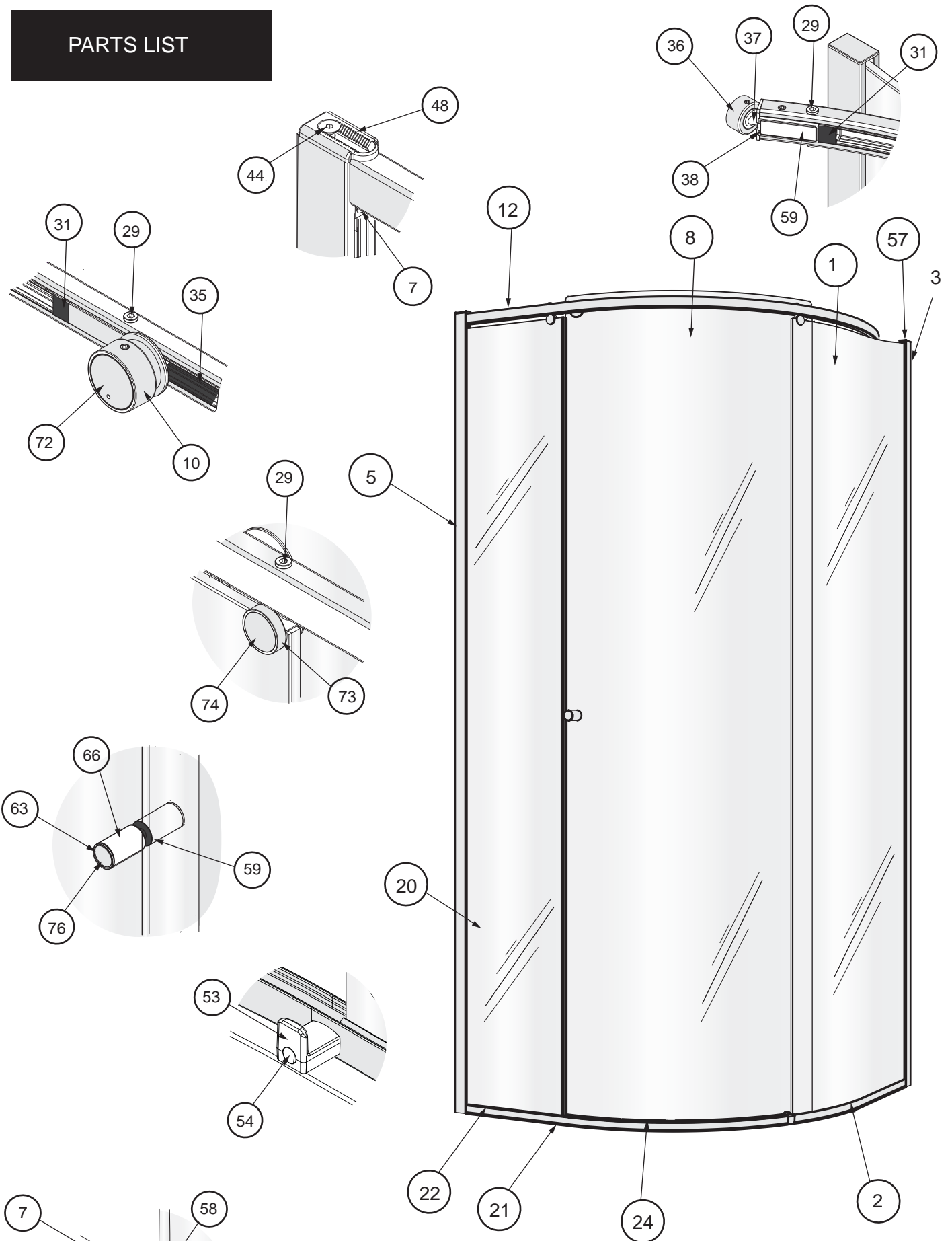

CURVED SLIDER DISK KIT OF PARTS (7370 AF)

ITEM	DESCRIPTION	PART No	QTY
*72	ROLLER BLOCK BODY COVER CAP	8408 A SILVER	2
73	DECO DISK COVER RING	8252 A SILVER	6
*74	DECORATIVE PIVOT DISK	8652 A SILVER	6
*75	DECORATIVE HANDLE CAP	8400 A SILVER	2
76	DIN O-Ring 0140-20	8582 AF	2
77	MTK1 SLIDER & CURVED DISK DISPLAY PACK	4681 AF	1
78	MATKI CHROME EMBLEM	1005 CHROME	1

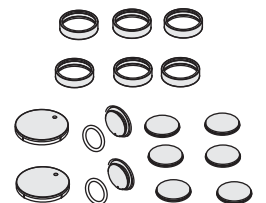

PARTS LIST

* colour variant on parts

SLIDER DOOR PACK

ITEM	DESCRIPTION	PART No	QTY
1	CURVED FIXED PANEL	7699 M CLEAR/PLAIN(LH) / 7698 M CLEAR/PLAIN(RH)	1
2	CURVED PANEL FLOOR RAIL	8717 A SILVER(LH) / 8730 A SILVER(RH)	1
*3	CURVED FIXED PANEL WALL MOUNT	8727 A SILVER/BLACK/WHITE/BRONZE	1
4	BS nsp 5mm DIA FOAM CORD INSERT	1752 AF	8
*5	SLIDER WALL MOUNT	7605 A SILVER/BLACK/WHITE/BRONZE	1
6	WALL MOUNT GLASS GUARD	8415 GREY/WHITE/BLACK	1
7	WALL MOUNT LOCKING SCREW	8266 AF	1
8	CURVED DOOR GLASS	7704 M CLEAR/PLAIN(LH) / 7703 M CLEAR/PLAIN(RH)	1
9	SLIDER VERTICAL SEAL	8820 CLEAR & 8819 CLEAR	3
10	111 SLIDER ROLLER BLOCK ASSEMBLY	7362 AF	2
11	CURVED CORNER FLOOR RAIL BLOCK	8444 AF	1
12	M5 x 10 CSK SKT	1488 A SILVER	1
13	M5 X 12 SOCKET DOMED ST.ST	1282 A SILVER	2
14	CURVE FLOOR RAIL ADJUSTER	8449 A SILVER	1
15	ADJUSTER CLAMP	8427 AF	1
16	PIVOT BLOCK ADJUSTER SCREW	8261 AF	1
*17	MATKI ONE CURVED DISK KIT OF PARTS	7370 AF (SILVER/BLUE/GREEN/RED/GOLD/COPPER/BRASS/WHITE/BLACK)	1
18	MATKI ONE CURVED SLIDER INSTALLATION INSTRUCTIONS	0950 AF	1
*19	MATKI ONE CURVED SLIDER KIT OF PARTS	7371 A SILVER (BRASS/COPPER)	1

PANEL PACK

ITEM	DESCRIPTION	PART No	QTY
20	STRAIGHT FIXED PANEL GLASS	7700 M CLEAR/PLAIN(900) / 7718 DGG PLAIN(1000) / 7701 M CLEAR/PLAIN(1200) / 7702 M CLEAR/PLAIN(1500)	1
21	STRAIGHT PANEL FLOOR RAIL	8714 A SILVER(900) / 8709 A SILVER(1000) / 8715 A SILVER(1200) / 8716 A SILVER(1500) (RH) 8711 A SILVER(900) / 8708 A SILVER(1000) / 8712 A SILVER(1200) / 8713 A SILVER(1500) (LH)	1
22	CURVED STRAIGHT PANEL GLASS RAIL	8724 A SILVER(900) / 8720 A SILVER(1000) / 8725 A SILVER(1200) / 8726 A SILVER(1500)	1
23	THRESHOLD END CAP	8409 WHITE	1
24	SLIDER THRESHOLD COVER	8723 A SILVER	1
25	M5 x 10 CSK SKT	1488 A SILVER	2
26	ADJUSTER CLAMP	8427 AF	1
27	BOTTOM WALL CORNER BRACKET	8431 AF	1
28	CURVED TOP TRACK	8740 A SILVER(900) / 8739 A SILVER(1000) / 8741 A SILVER(1200) / 8742 A SILVER(1500)	1
29	PIVOT BLOCK ADJUSTER SCREW	8262 AF	2
30	SMALL WHITE DAMPER	1339 AF	2
31	SLIDER WHEEL STOP	8416 BLACK	4
32	SLIDER TOP TRACK END	8429 A SILVER	2
33	TOP TRACK SPACER	8863 AF (CUT TO LENGTH)	1
34	CURVED MIDDLE TOP TRACK BRACKET	8450 A SILVER	1
35	111 CURVED INTERNAL ROLLER -TRACK PROF	8804 BLACK	2
36	CURVED WALL PLATE	8447 A SILVER	1
37	WALL PLATE ADJUSTER	8445 A SILVER	1
38	TOP TRACK ADJUSTER END BRACKET	8451 A SILVER	1
39	INSTALLATION DOOR SUPPORT	8592 BLACK	2
40	M5 X 10 SOCKET SET SCREW A2	1467 A SILVER	2
41	M5 X 6 SOCKET SET SCREW A2	1502 A SILVER	2
42	PIVOT BLOCK ADJUSTER SCREW	8261 AF	2
43	PIVOT CLAMP BODY	8436 A SILVER	2
44	M5 x 20 CSK SKT	1503 A SILVER	3
45	DIN O-Ring 0190-20	8579 AF	4
46	M4 X 4 SOCKET SET SCREW A2	1298 A SILVER	4
47	SLIDER PIVOT CLAMP GUARD	8432 GREY	2
48	SLIDER WALL MOUNT TOP CAP	8407 AF	1
49	NO. 8 X 12 CSK POZI S TAP ST/ST	1442 A SILVER	1
50	M.Y MOD SOCK SET + ST.ST BEARING(MIS3432)	8581 AF	2
51	WHITE PTFE ROD 6mm DIA	1306 AF	0.55
52	111 SLIDER GUIDE BLOCK ASSEMBLY	7363 AF	1
53	CURVED SLID GUID BLK	8960 AF	1
54	CURVED DOOR GUIDE CAP	8961 AF	1
55	NO.6 X 30 CSK	1493 A SILVER	1

CURVED SLIDER KIT OF PARTS (7371 AF)

ITEM	DESCRIPTION	PART No	QTY
56	WALL PLUG	1818 AF	7
57	3mm AF BALL END	8622 AF	1
58	BRACKET HOLE COVER	8435 A SILVER	1
59	ADJUSTER END COVER PLATE	8448 A SILVER	1
60	CURVED WALL MOUNT CAP	8446 A SILVER	1
61	ADJUSTER END COVER PLATE	8448 A SILVER	1
62	HANDLE WASHER	8439 GREY	2
*63	HANDLE CAP WASHER	8257 A SILVER	2
64	HANDLE CENTRAL BAR	8250 A SILVER	1
65	CSK SKT SCREW	1417 A SILVER	2
*66	HANDLE SLEEVE	7645 A SILVER	2
67	No.8 x 38 PAN HEAD POZI S TAP ST/ST	1210 A SILVER	6
68	No.8 x 50 PAN HEAD POZI S TAP ST/ST	1492 A SILVER	1
69	CURVE FLOOR RAIL ADJUSTER	8449 A SILVER	1
70	PIVOT BLOCK ADJUSTER SCREW	8261 AF	1
71	ADJUSTER CLAMP	8427 AF	1

