

# matki

## MATKI ONE MOPR - RECESS INLINE PIVOT

INSTALLATION

PARTS LIST

Please pass the  
Guarantee Card  
to the customer.



CE

matki

13

Matki PLC, Churchward Road, Yate,  
Bristol BS37 5PL

EN 14428:2008+A1

**MATKI PLC, CHURCHWARD ROAD, YATE, BRISTOL, BS37 5PL**  
TELEPHONE:01454 322888 (CUSTOMER SERVICES) EMAIL: techsupport@matki.co.uk

## IMPORTANT

### TOOLS REQUIRED

Masonry Drill bit 6mm, Tape Measure, Screw Drivers, Safety Glasses, Electric Drill, Level, Pencil, Adjustable Spanners, Non Slip Gloves, 2mm/3mm/4mm Allen Keys

Before disposing of carton and/or commencing assembly, please check all the parts to ascertain that none are missing and they are all undamaged. No claim for missing/damaged parts will be accepted once the packing carton has been disposed of and/or assembly has commenced.

In case of query contact your Stockist with details of model number and details of serial number.

### PREPARATION IMPORTANT

1. Please read complete installation instructions before fitting for Enclosure and Tray (if fitting).
2. We recommend the use of Safety glasses and Non slip gloves when handling the glass panels.
3. Ensure that the product can be **fixed to a solid masonry wall** or suitable **timber stud work grade C16/C24** in the area behind the Wall frames.
4. Shower trays or tiled floors **must be absolutely level** where enclosures are fitted
5. If fitting a tray we recommend a **drainage test** is carried out before the tray is tiled in position.
6. The assembly should be installed onto a waterproof wall covering and installed after the Tray and wall coverings are in place. Where Tiling lips are provided Trays should be let into the Wall with the Tiling lip flush with the wall to allow the Tiling to overlap the Tiling lip.
7. Seal between tray and tiles. Remove any excess sealant from the area/joint between the tray and the tiles where the Wall Mount is to be fitted. This will ensure the Wall mount fits correctly to the wall and tray/or tiled floor.

**CAUTION: TEMPERED GLASS CANNOT BE CUT, POLISHED METAL AND CHROME CAN BE SCRATCHED. CAREFULLY REMOVE ASSEMBLY FROM CARTON, DO NOT PLACE GLASS ON HARD FLOOR OR EXPOSE EDGES TO IMPACT.**

## DIMENSIONS

RECESS INLINE PIVOT  
1000/1100/1200

LH OPENING  
(AS FACTORY ASSEMBLED)

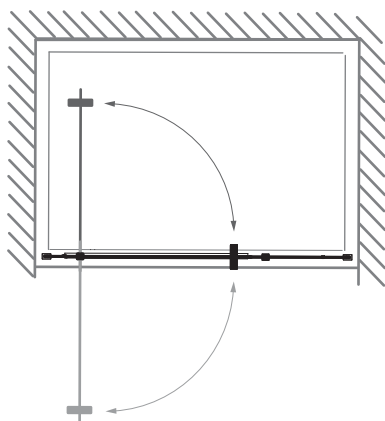

RH OPENING

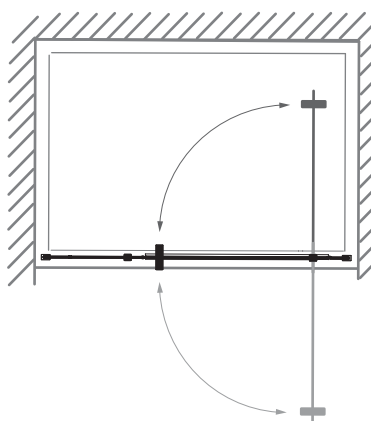

Model	A	B	C	D
MOPR1000	960-1000	80-100	482	329-349
MOPR1100	1060-1100	80-100	522	389-409
MOPR1200	1160-1200	80-100	622	389-409

Dimensions are approximate

## STAGE 1

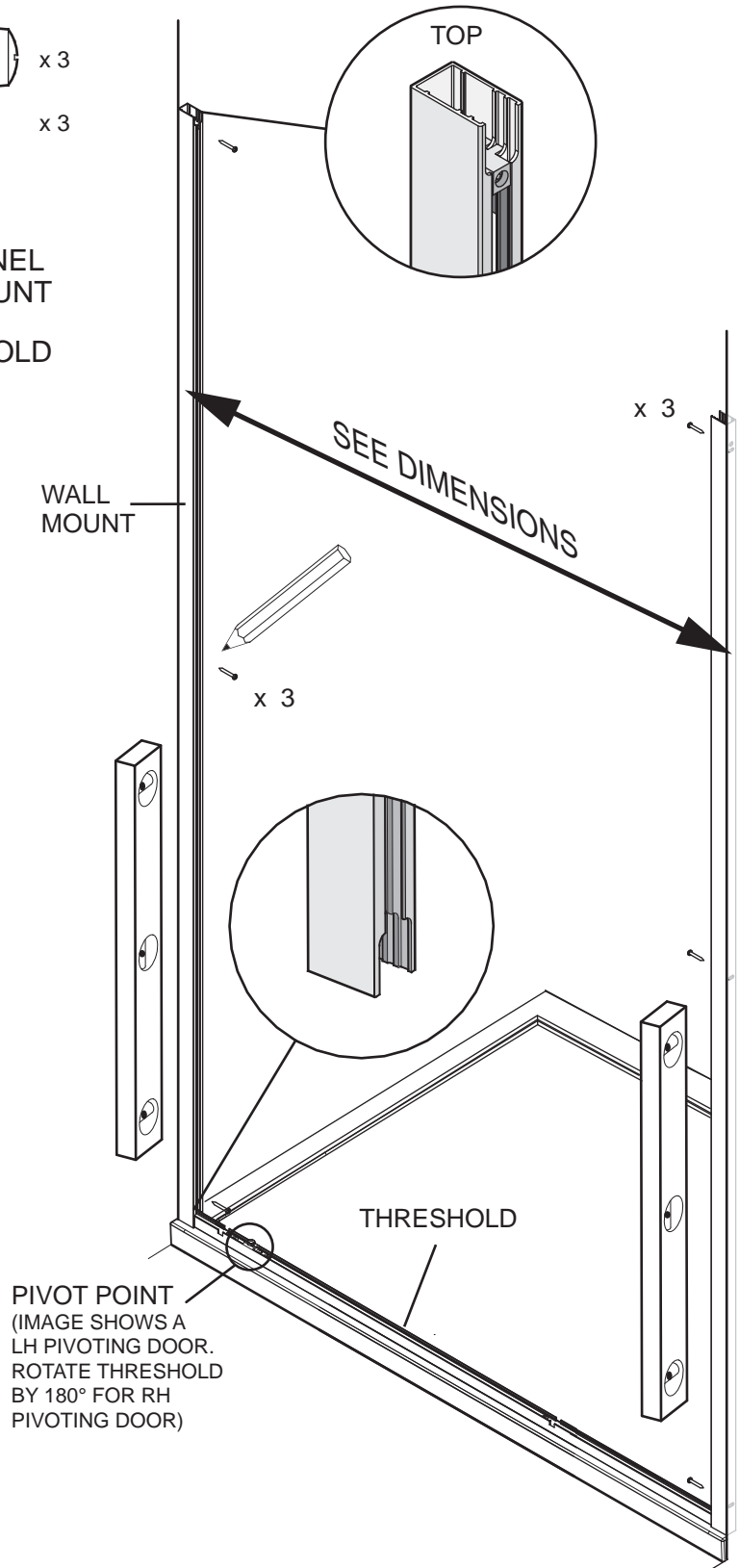
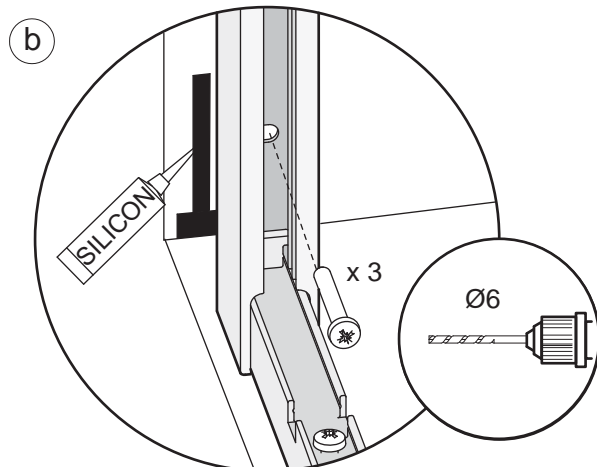
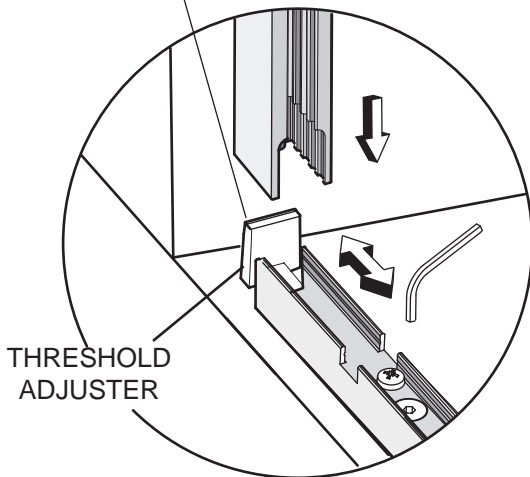
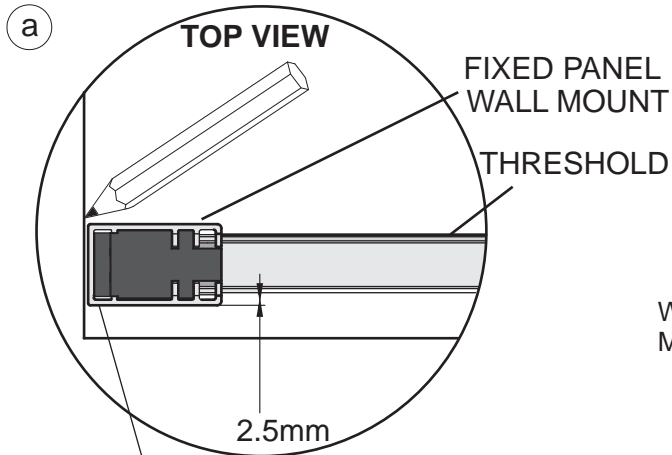
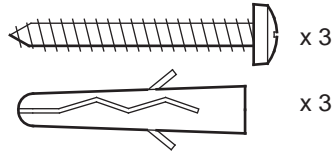

**This stage is describing the fitting of the Fixed panel wall mounts**

**Before fitting the enclosure please check that your product will fit the finished aperture size.(See dimensions)**

**a.** Remove and set aside the threshold cover from the horizontal threshold. Place the horizontal threshold into position on tray. (If fitting close to the front edge of the tray take into account that the front face of the fixed panel wall mount sits 2.5mm in front of the threshold). The Pivot point in the threshold determines the handing of the door, for a door pivoting from the LH side, pivot point should be on the LH side, and right for RH pivoting. Position the closure fixed panel wall mount on to the wall over threshold (wall mount has a top and bottom, Wall mount cut-out with socket set screw is the top of the wall mount). Ensure the threshold adjuster fits up into the back of the wall mount extrusion in the recess as shown. Adjust position of threshold adjuster as required, to adjust loosen screw 1 full turn, re-tighten after adjustment, do not over tighten. Plumb the wall mount for upright and mark the fixing holes in the centre of the slots.

**b.** Drill 3 x fixing holes in the wall and insert wall plugs. Clean area and apply silicon sealant to the area behind the wall mount between the tray and tiles and 100mm up the wall, central to the width of the wall mount. Fit the wall mount using the No.8 x 32mm Pan Head Screws.

**c.** Repeat as above for fixed panel wall mount on the pivot block side.

## STAGE 2

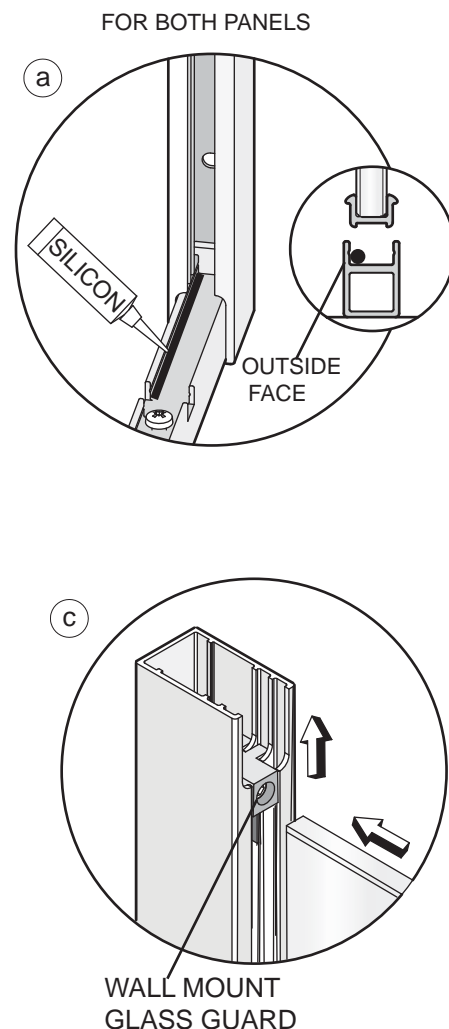
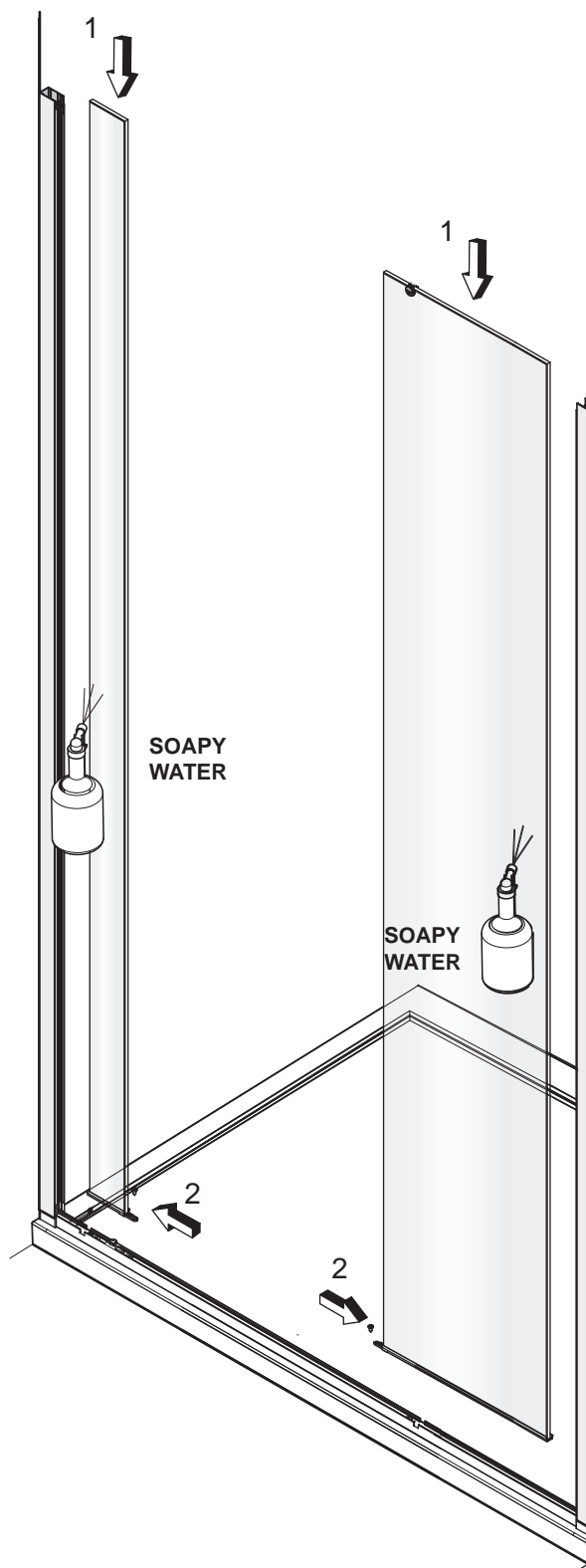
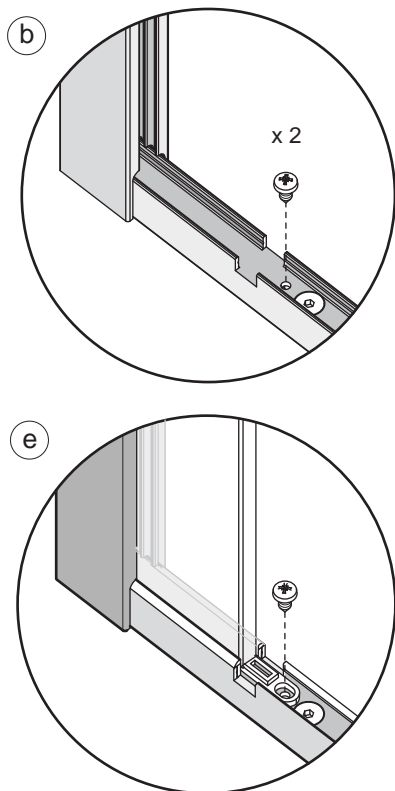

**This stage is describing the fitting of both fixed panels. Before fitting the fixed glass panels adjust the threshold extrusion so that it is equally positioned between the two wall mounts. Loosen the threshold adjusters at each end and lightly tighten in position as required.**

- a.** Apply a bead of silicon along the outer inside edge of the threshold extrusion in the recess provided up to the cut-out where both fixed panels will be fitted.
- b.** Remove and set aside the panel stop fixing screws from the threshold extrusion.
- c.** Make sure the wall mount glass guard is pushed up fully to allow the glass to easily slot into the wall mount.
- d.** Lightly wet the edge of the fixed panel with soapy water and gently lower the panel down into the threshold extrusion first then along into the wall mount.
- e.** As a guide the end of the edge of the fixed panel glass and extrusion should be positioned inline with the start of the cut out in the threshold track (d) further slight adjustments may be required during the fitting of the door. Fix into position using the previously removed screw.
- f.** Repeat as above (c-d) for the opposite panel.

## STAGE 3

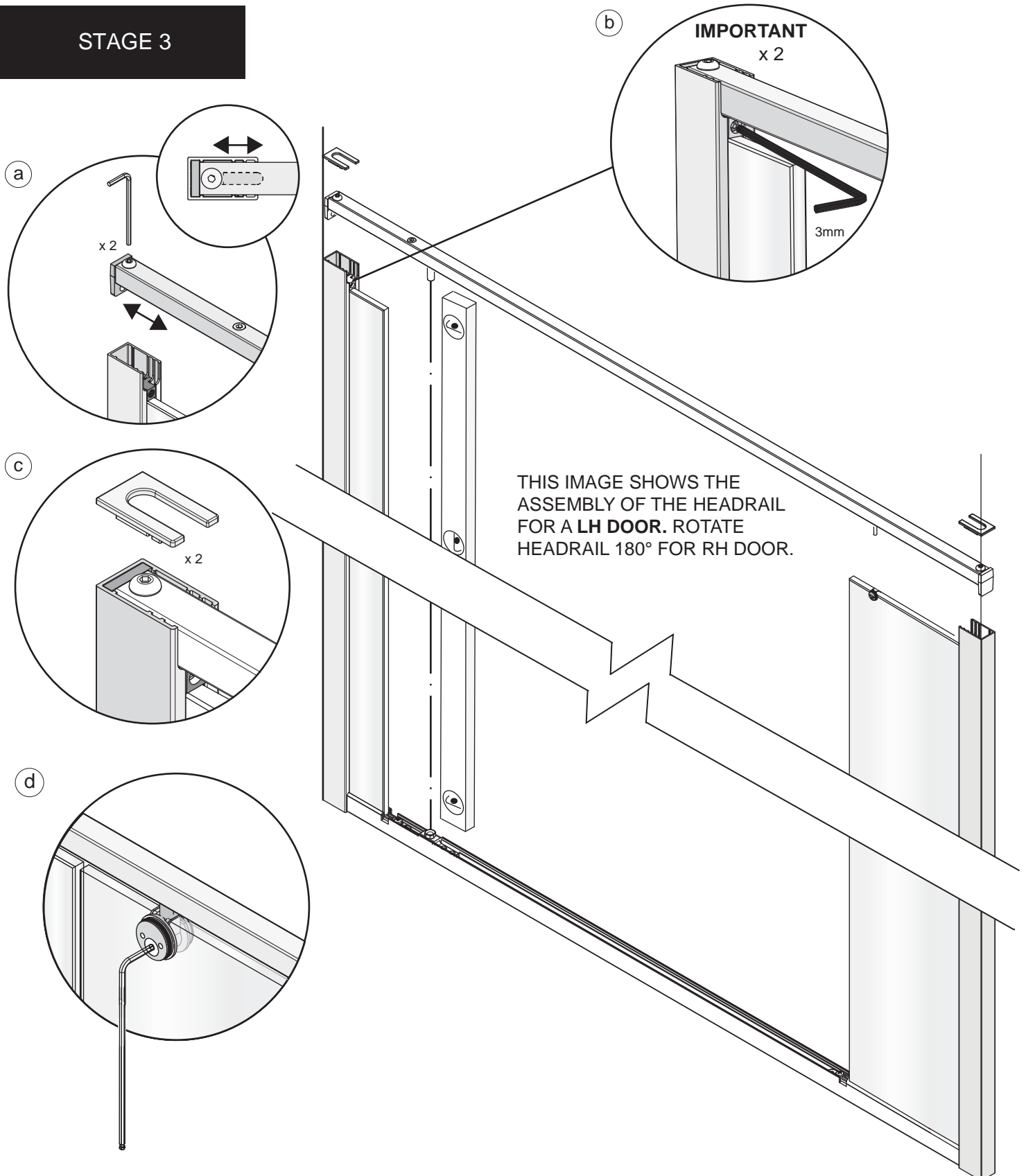

### This stage is describing the fitting of the Top Track.

**a.** Loosen the fixings in the headrail adjusters to allow the adjusters to move freely in and out. Lower the top track into position, ensuring the tongues on the headrail adjusters fit down into the back of the wall mounts. Using a long spirit level align the upper and lower pivot points by adjusting the headrail left or right. Re-tighten the fixings in the headrail adjusters to fix in position.

**b. Important** - tighten the top track locking screws underneath the top track on both wall mounts to fix the top track to the wall mounts.

**c.** Fit both the wall mount top caps (supplied in the kit of parts) to the top of the wall mounts.

**d.** Tighten the inline panel clamp to the headrail.

## STAGE 4

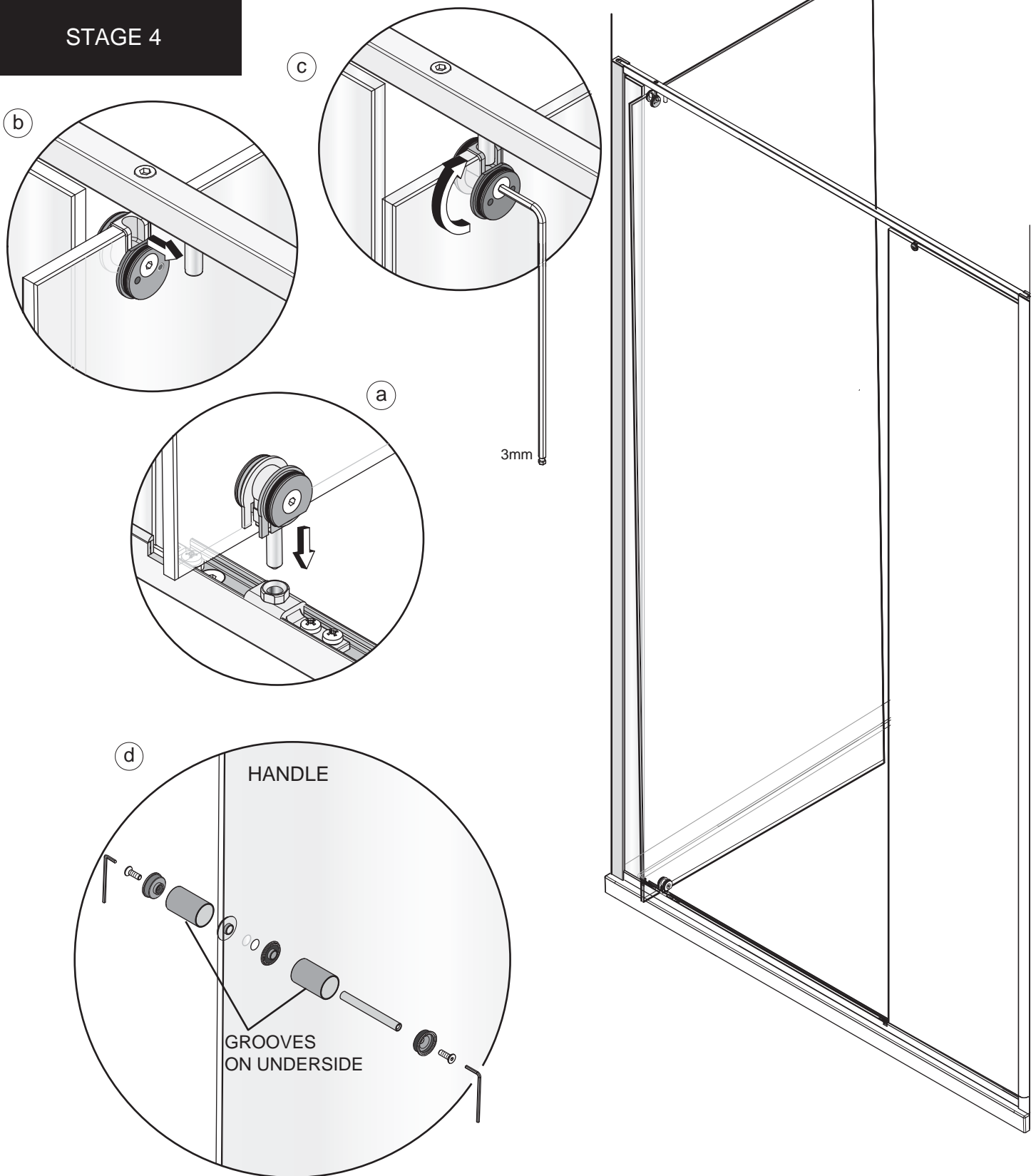

**This stage is describing the fitting of the Door.**

- Lift the door and carefully guide the lower pivot block pin into the pivot block fitted to the threshold track.
- From behind guide the upper pivot block pin fixed to the headrail into the cup in the pivot block fitted to the top of the door.
- Rotate the pivot block disc with the socket csk screw 180° so that it secures the door in position. Tighten the socket csk screw.
- Disassemble the handle by unscrewing the 2 x M5 x 12 Csk socket screws. Place the glass washers either side of the 2 holes in the door glass. Re-assemble the handle to the glass and tighten into position with the grooved surfaces on the handle on the underside.

## STAGE 5

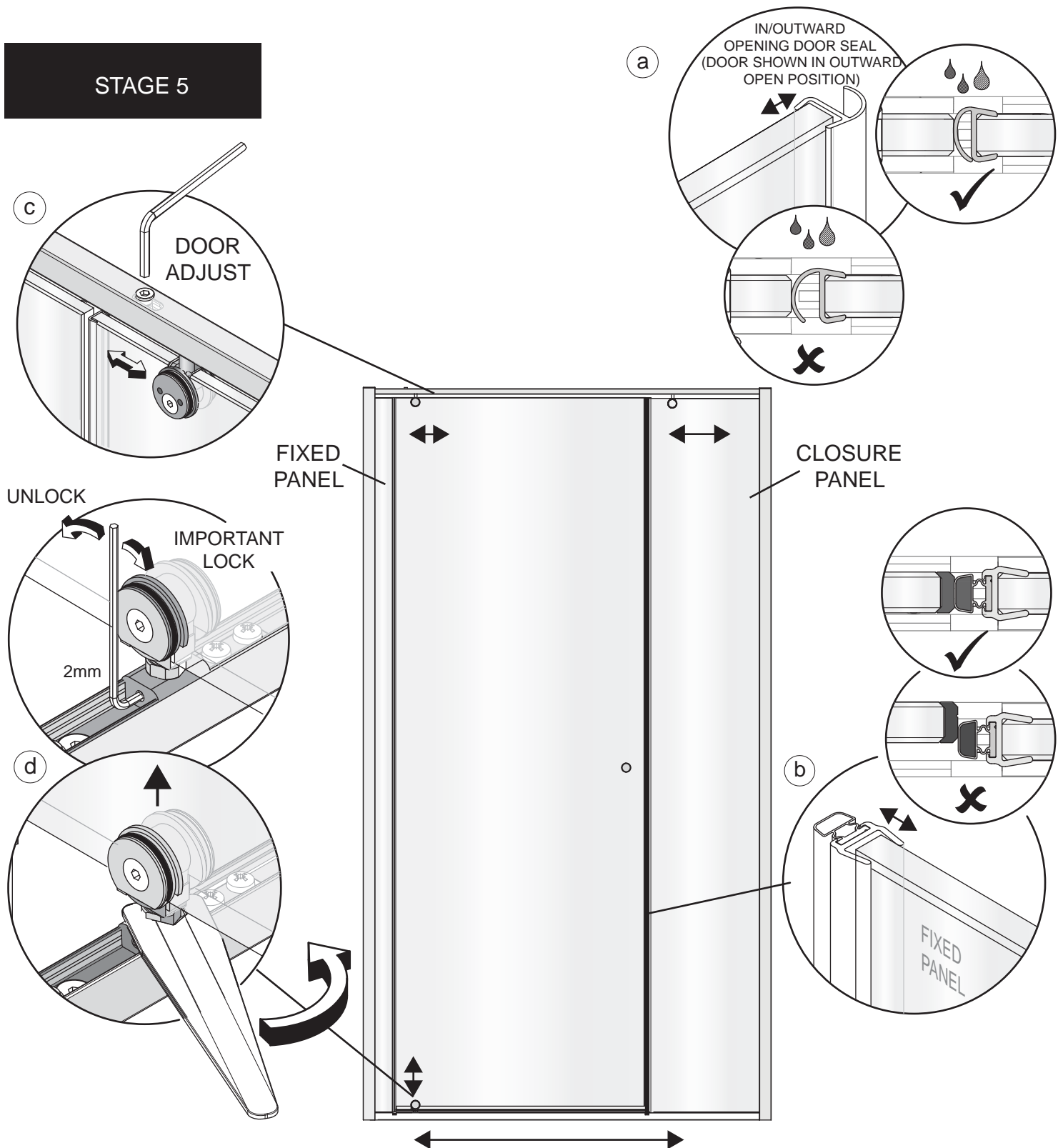

### This stage is describing the Door adjustment.

**a.** Fit the door closure seal to the back of the door. The door closure seal can be adjusted away from the edge of the door to improve sealing with the fixed panel or the fixed panel can be adjusted at the top to the seal. **Important. The inward/outward seal requires sufficient compression to the fixed panel glass.** When initially opening the door both inwards and outwards the seal may deform unevenly and can catch the fixed panel. Allow the seal to take a set in the closed position for 12 -24 hrs. Open the door inwards and outwards adjust as required ensuring the seals works effectively for both directions of movement.

**b.** Fit the magnetic closure panel seal to the edge of the closure panel. Check the polarity of the magnet is correct with the magnet on the edge of the door. This seal can be adjusted away from the edge of the fixed panel to meet the door magnetic seal or the fixed panel can be adjusted at the top to the door. Check there are no gaps between the door and magnetic closure panel seal.

**c.** To adjust the door left to right at the upper pivot point, loosen the socket cap screw in the top of the headrail by one turn only and adjust the door as required.

**d.** To adjust the door up and down at the lower pivot point, firstly loosen the locking screw in the lower pivot block. Then using the spanner (supplied in the kit of parts) wind the nut at the base of the pivot block anti-clockwise to raise the door upwards. **Important - Re-tighten locking screw**

## STAGE 6

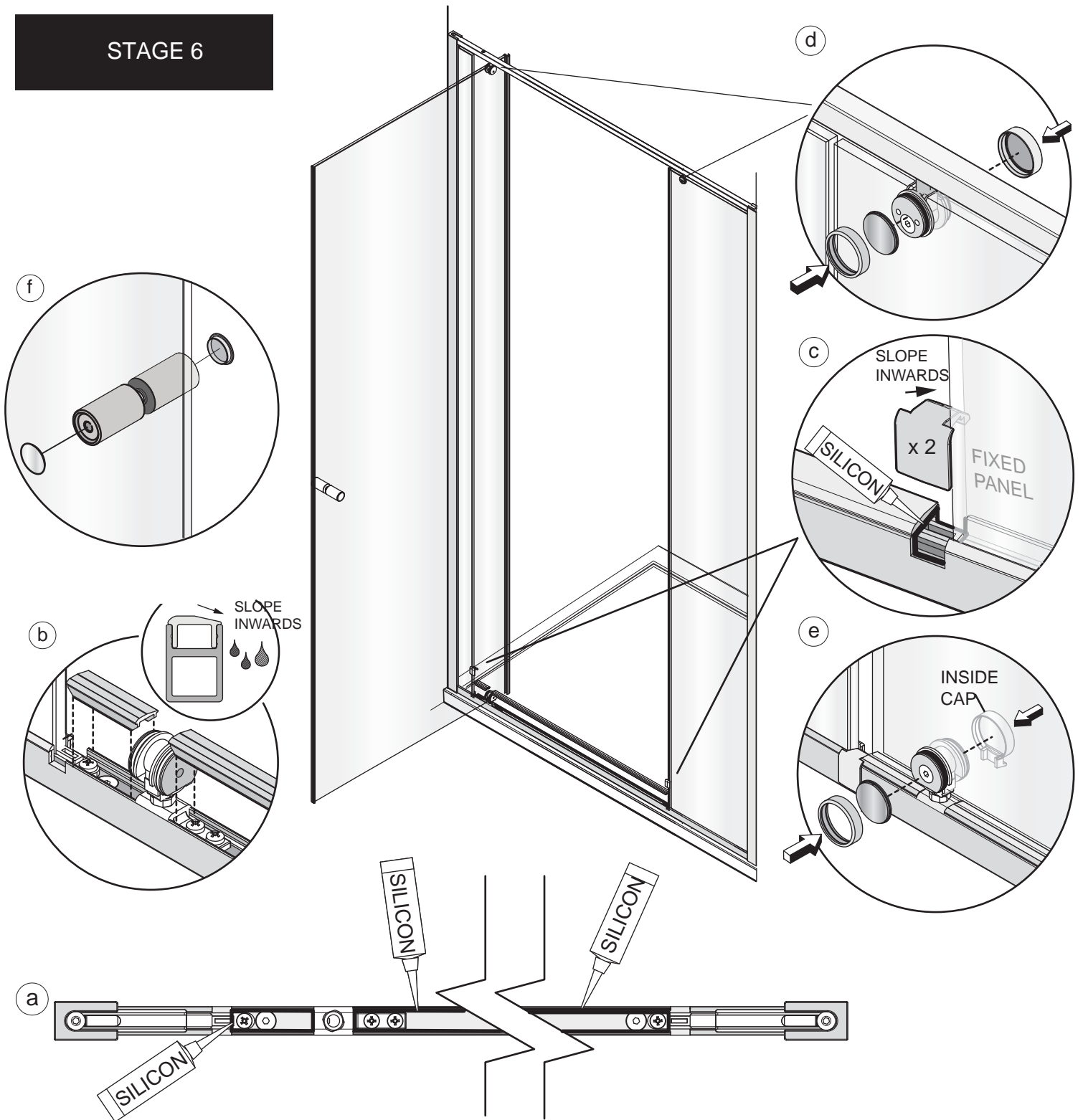

**This stage is describing the fitting of the covers and caps.**

**a.** Apply a continuous bead of silicon all around the inside of the troughs in the threshold track between the edge of the fixed panel and the lower pivot block and between the other side of the lower pivot block and edge of the closure fixed panel, as shown above.

**b.** Fit the two covers either side of the lower pivot block into the threshold track, so that the face of the covers is firmly pressed against the face of the lower pivot block and ensure the slope on the cover is facing inward.

**c.** Apply a bead of silicon all around the inside of the recess in the threshold track where the threshold cover caps are to be fitted, from the edge of the threshold cover all the way around to the edge of the fixed glass panel. Fit the threshold cover caps (supplied in the kit of parts), with the slope facing inwards.

**d.** Fit the upper pivot block covers with colour detail disks over both sides of the upper pivot block and inline panel clamp. The inline panel clamp covers are factory fitted on the panel for silver, black and white units. Remove and refit with the colour disks. The Inline clamp covers are not fitted on bronze products or with optional copper and brass handle variants. These are included in the parts kit.

**f.** Fit the handle cover caps, press firmly into the ends of the handle.



## STAGE 7

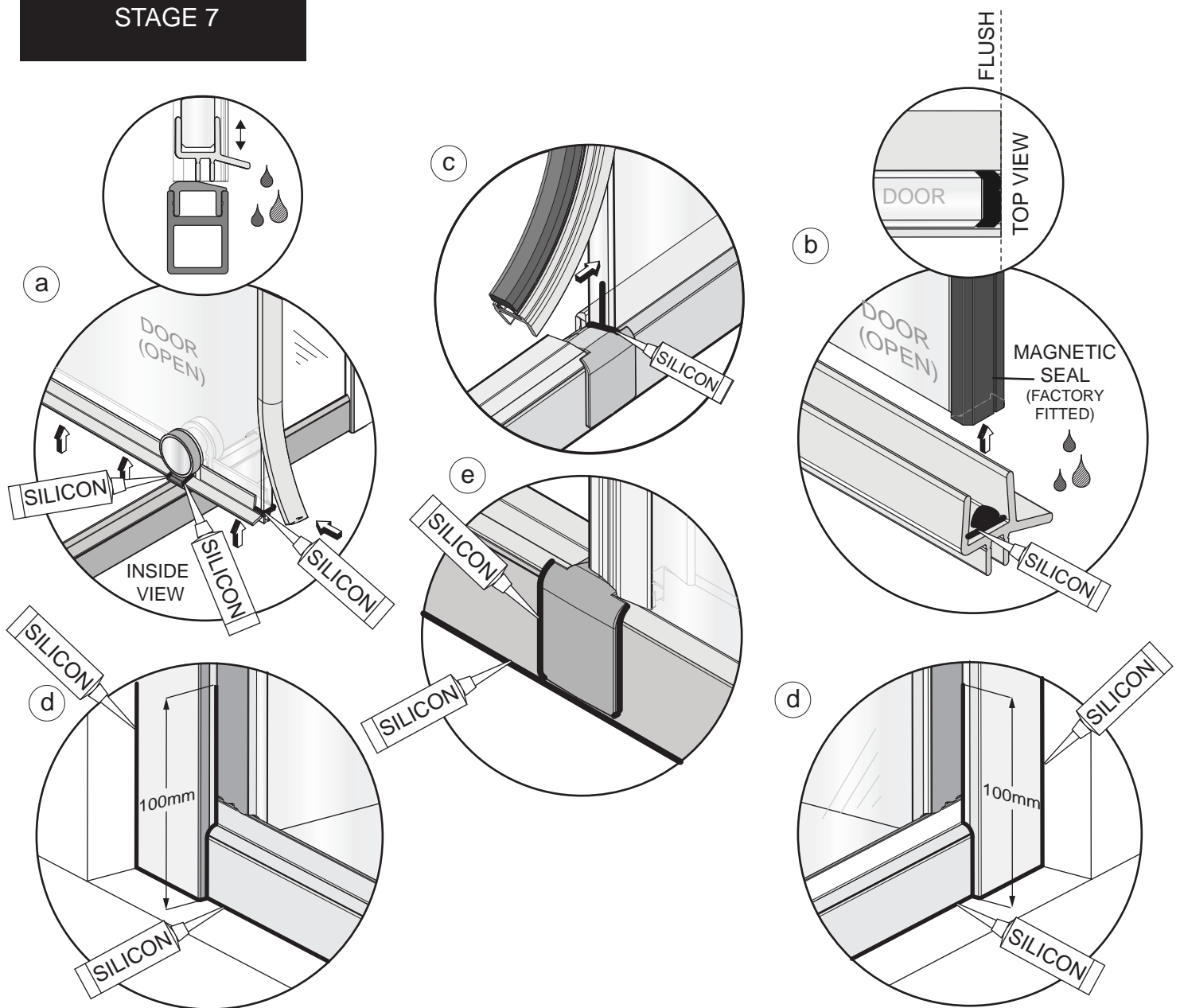

### This stage is describing the final fitting of the Seals and Silicon

- a.** Fit the door horizontal seals to the bottom of the door, ensuring that the ends of the seal are firmly pressed up against the side of the lower pivot block on both sides. The horizontal seal deflector faces inwards. Adjust the Horizontal door seals down as required to meet the threshold. Pull off the vertical seal at the bottom on the pivot side and apply a bead of silicon sealant at the end of the horizontal seal, refit the vertical seal. Apply a small bead of silicon to the joints where the horizontal seals meet the inside pivot block cap.
- b.** The end of the horizontal seal must be flush with the edge of the door. Apply a bead of silicon sealant between the bottom of the door and the horizontal seal, clean the silicon flush with the door edge.
- c.** Pull off the closure panel vertical magnetic seal at the bottom. Apply a bead of silicon along the top of the threshold cover cap and vertical edge of the glass panel and refit the magnetic seal to the edge of the glass.
- d.** Apply a thin bead of silicon along the bottom edge of both the wall mounts and all the way up the outside of both the wall mounts and the tiles. Apply a thin bead all the way along the threshold between the extrusion and finished floor surface/tray. Continue around the joint where the threshold joins the wall mounts and also 100mm up on the outside where the wall mount and glass meet.
- e.** Apply a bead of silicon on the outside around the joints between the threshold cover caps and threshold extrusion. Masking tape can be used to achieve a tidy edge to the sealant. Remove the masking tape immediately and allow the silicon to cure for 24 hours before using the shower.

# PARTS LIST

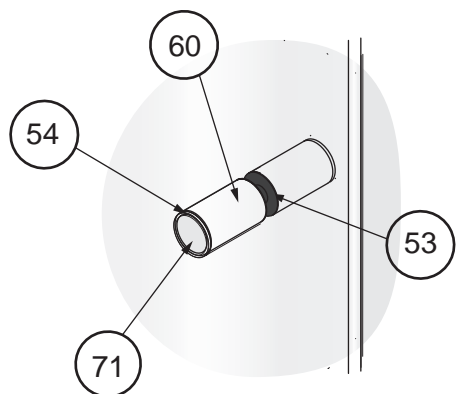
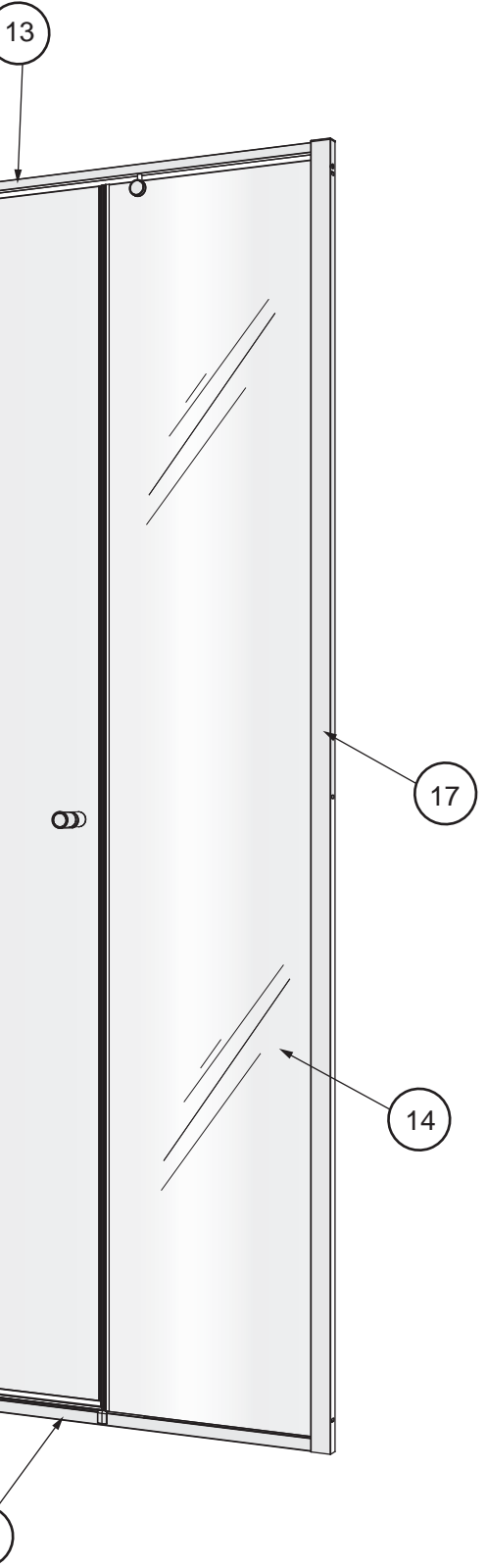
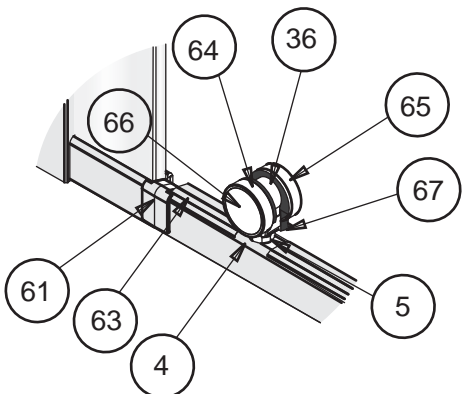
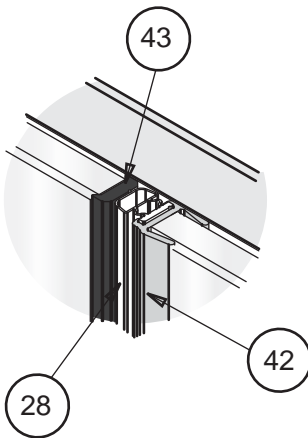
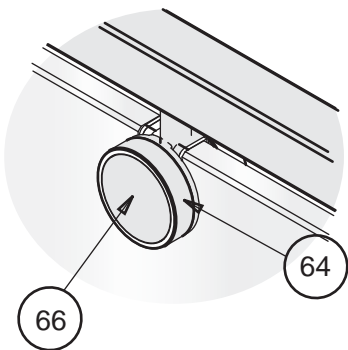
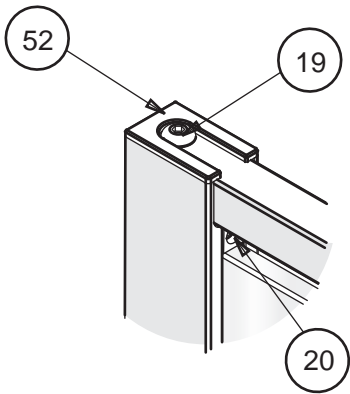

# PARTS LIST

\* colour variant on parts

## MAIN INLINE PIVOT PACK

ITEM	DESCRIPTION	PART No	QTY
1	PIVOT CLOSURE PANEL	7657 M CLEAR/PLAIN	1
2	PIVOT CLOSURE PANEL RAIL	8426 A SILVER	1
3	No.8 x 9.5 PAN POZI S.TAP ST.ST SCREW	1420 A SILVER	1
4	PIVOT BLOCK	8423 AF	1
5	PIVOT HEIGHT ADJUSTER	8258 AF	1
7	DIN 916 M4 X 8 SOCKET SET SCREW ST.ST	1360 A SILVER	1
8	TOP PIVOT PIN	8253 AF	1
9	ADJUSTING PIVOT BLOCK	8589 A SILVER	1
10	ADJUSTER CLAMP	8427 AF	1
11	PIVOT BLOCK ADJUSTER SCREW	8261 AF	1
12	INLINE RECESS FLOOR RAIL	8573 A SILVER (1000) / 8574 A SILVER (1100) / 8575 A SILVER (1200)	1
13	INLINE RECESS TOP TRACK	8576 A SILVER (1000) / 8577 A SILVER (1100) / 8578 A SILVER (1200)	1
14	INLINE RECESS PANEL	7672 M CLEAR/PLAIN (1000) / 7673 M CLEAR/PLAIN (1100,1200) / ??? M CLEAR/PLAIN (1400) / ??? M CLEAR/PLAIN (1500)	1
15	INLINE RECESS GLASS PANEL RAIL	8586 A SILVER (1000) / 8587 A SILVER (1100,1200)	1
16	PIVOT THRESHOLD COVER	7630 A SILVER (1000) / 7631 A SILVER (1100) / 7632 A SILVER (1200)	1
*17	PIVOT WALL MOUNT	7628 A SILVER/ WHITE/BLACK/BRONZE	2
*18	WALL MOUNT GLASS GUARD	8415 GREY/WHITE/BLACK	2
19	M5 X 12 SKT DOMED ST.ST	1282 A SILVER	2
20	WALL MOUNT LOCKING SCREW	8266 AF	2
21	BS nsp 5mm DIA FOAM CORD INSERT	1752 AF	8
22	INLINE NOTCH CLAMP BODY	8404 GREY	1
23	INLINE NOTCH PIVOT GUARD	8403 GREY	1
24	PIVOT BLOCK CAP	8254 A SILVER	2
25	INLINE PIVOT BLOCK CAP	8401 A SILVER	1
26	QUINTESSA NOTCH CLAMP PIN	8639 AF	1
27	DIN O-Ring 0190-20	8579 AF	6
28	PIVOT DOOR MAGNET	8679 AF	1
29	HORIZONTAL DOOR SEAL	8598 CLEAR	1
30	RECESS DOOR	7662 M CLEAR/PLAIN (1000) / 7663 M CLEAR/PLAIN (1100) / 7662 M CLEAR/PLAIN (1000)	1
31	PIVOT V DOOR CLOSURE SEAL	8618 AF	1
32	TOP PIVOT BLOCK	8422 A SILVER	1
33	PIVOT SLEEVE TOP	8413 GREY	1
34	TOP PIVOT GUARD	8417 GREY	1
35	M5 X 20 CSK SKT SCREW ST.ST	1503 A SILVER	3
36	PIVOT PIN	8421 AF	1
37	PIVOT DISK WITH COUNTERSINK	8255 A SILVER	1
38	PIVOT DISK WITH BOSS	8256 A SILVER	1
39	BOTTOM PIVOT GLASS BUSH	8414 GREY	1
40	BOTTOM PIVOT GLASS BUSH 2	8418 GREY	1
41	M5 x 10 CSK SOCKET ST.ST	1488 A SILVER	2
42	PIVOT DOOR MAGNET CARRIER	8762 CLEAR	1
43	PIVOT DOOR CLOSURE MAGNET C0923	8645 AF	1
44	MATKI ONE RECESS INLINE PIVOT INSTALLATION INSTRUCTIONS	0947 AF	1
*45	MATKI ONE PIVOT KIT OF PARTS	7364 A SILVER (7373 BRASS / 7373 COPPER)	1
46	MATKI ONE PIVOT DISK KIT OF PARTS (DETAIL PACK)	7372 AF (SILVER/BLUE/GREEN/RED/GOLD/COPPER/BRASS WHITE/BLACK)	1
47	DIN 557 -M6 SQUARE NUT ST.ST		1
48	DIN 916 M4 X 5 SOCKET SET SCREW ST.ST	1297 A SILVER	2
49	PIVOT CORNER CLOSURE PANEL RAIL	8678 A SILVER	1

## PIVOT KIT OF PARTS

ITEM	DESCRIPTION	PART No	QTY
50	WALL PLUG	1818 AF	6
51	3mm AF BALL END	8622 AF	1
52	WALL MOUNT TOP CAP	8441 A SILVER	2
53	HANDLE WASHER	8439 GREY	2
54	HANDLE CAP WASHER	8257 A SILVER	2
55	HANDLE CENTRAL BAR	8250 A SILVER	1
56	N.o8 x 38 PAN HEAD POZ S TAP ST/ST	1210 A SILVER	6
57	BRACKET HOLE COVER	7461 A SILVER	1
58	111 10mm OPEN-END SPANNER	7599 AF	1
59	M5 X 12 CSK SKT SCREW	1417 A SILVER	2
60	PIVOT DOOR HANDLE SLEEVE	8641 A SILVER	2
61	RAIL CAP	8677 A SILVER	2
62	PIVOT SIDE HORIZONTAL SEAL	2435 CLEAR	1
63	PIVOT THRESHOLD COVER SMALL	7629 A SILVER	1

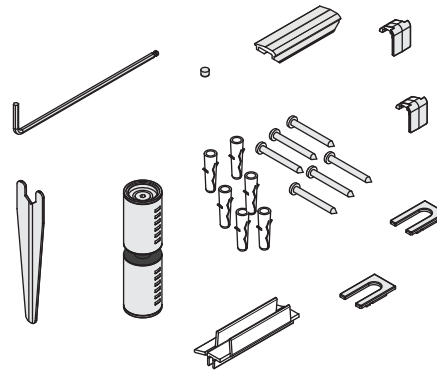

## PIVOT DISK KIT OF PARTS

ITEM	DESCRIPTION	PART No	QTY
64	DECO DISK COVER RING	8252 A SILVER	5
65	DECO DISK WITH CUT OUT	8269 A SILVER	1
*66	DECORATIVE PIVOT DISK	8652 A SILVER	5
*67	DECO DISK WITH SEAL	8440 A SILVER	1
*68	DECORATIVE HANDLE CAP	8400 A SILVER	2
69	DIN O-Ring 0140-20	8579 AF	2
70	MTKI PIVOT & QUINT DISPLAY PACK	4682 AF	1
71	MATKI CHROME EMBLEM	1005 CHROME	1

